

# NPTF THREADED IN-LINE FLANGES

JIS B 2291 BOLT PATTERN (210K)										TYPE SH(A & B)				
FLANGE SIZE	PIPE SIZE	PART NUMBER	A	B	C	Emm	E	F	Gmm Jmm	K NPTF	MOUNTING KIT®			WT
											PART NO.	SCREW SIZE	O-RING	
<b>15</b>	<b>1/2</b>	6507-08-08DM	2.50	1.25	1.25	40.0	1.574	.63	11.0	1/2	MKM 5507	M10 x 50	G25	1.9
		6508-08-08DM							M10x1.5					
<b>20</b>	<b>3/4</b>	6507-12-12DM	2.75	1.38	1.25	45.0	1.772	.75	11.0	3/4	MKM 5508	M10 x 50	G30	2.3
		6508-12-12DM							M10x1.5					
<b>25</b>	<b>1</b>	6507-16-16DM	3.25	1.62	1.50	53.0	2.086	1.00	13.0	1	MKM 4588	M12 x 60	G35	3.8
		6508-16-16DM							M12x1.75					
<b>32</b>	<b>1 1/4</b>	6507-20-20DM	3.50	1.75	1.50	63.0	2.480	1.25	13.0	1 1/4	MKM 4589	M12 x 60	G40	4.2
		6508-20-20DM							M12x1.75					
<b>40</b>	<b>1 1/2</b>	6507-24-24DM	4.00	2.00	1.75	70.0	2.756	1.50	18.0	1 1/2	MKM 5509	M16 x 70	G50	6.1
		6508-24-24DM							M16x2					
<b>50</b>	<b>2</b>	6507-32-32DM	4.50	2.25	1.75	80.0	3.150	1.94	18.0	2	MKM 5521	M16 x 70	G60	7.3
		6508-32-32DM							M16x2					
<b>65</b>	<b>2 1/2</b>	6507-40-40DM	5.50	2.75	2.00	100.0	3.937	2.44	22.0	2 1/2	MKM 4592	M20 x 80	G75	12.8
		6508-40-40DM							M20x2.5					
<b>80</b>	<b>3</b>	6507-48-48DM	6.25	3.12	2.25	112.0	4.409	2.80	24.0	3	MKM 4593	M22 x 90	G85	17.9
		6508-48-48DM							M22x2.5					

MOUNTING KITS listed contain carbon steel bolts and Buna N O-Ring. To specify stainless Grade 18-8 bolts, add an SS at the end of the kit number (MK 501SS).

Please note that using stainless steel bolts may reduce the pressure rating of the assembly.

MATERIAL:  
**316L Stainless**

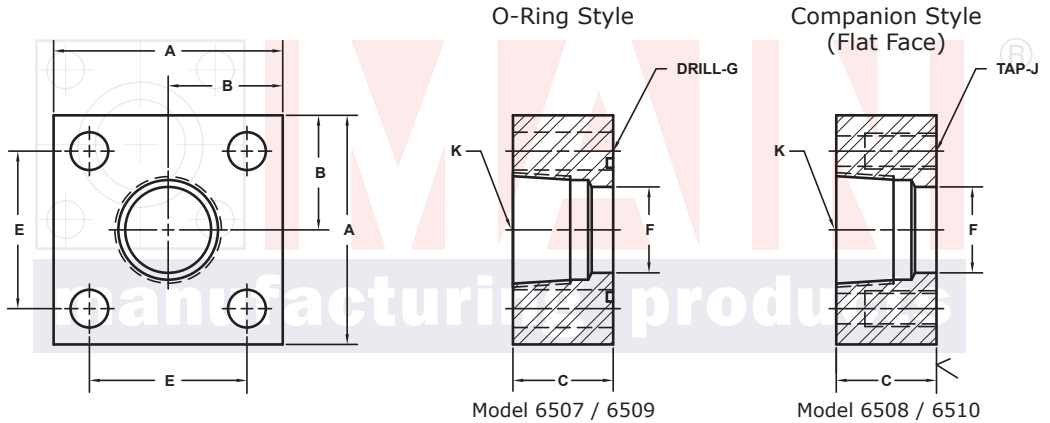

3181 TRI-PARK DR. GRAND BLANC, MI 48439 800-521-7918 810-953-1380 FAX 810-953-1385 INFO@MAINMFG.COM

JIS B 2291 BOLT PATTERN (210K)										TYPE SS(A & B)				
FLANGE SIZE	PIPE SIZE	PART NUMBER	A	B	C	Emm	E	F	Gmm Jmm	K NPTF	MOUNTING KIT®			WT
											PART NO.	SCREW SIZE	O-RING	
<b>15</b>	<b>1/2</b>	6509-08-08DM	2.25	1.12	1.25	36.0	1.417	.63	11.0	1/2	MKM 5507	M10 x 50	G25	1.4
		6510-08-08DM							M10x1.5					
<b>20</b>	<b>3/4</b>	6509-12-12DM	2.25	1.12	1.25	40.0	1.574	.75	11.0	3/4	MKM 5508	M10 x 50	G30	1.4
		6510-12-12DM							M10x1.5					
<b>25</b>	<b>1</b>	6509-16-16DM	2.75	1.38	1.50	48.0	1.890	1.00	13.0	1	MKM 4588	M12 x 60	G35	2.5
		6510-16-16DM							M12x1.75					
<b>32</b>	<b>1 1/4</b>	6509-20-20DM	3.00	1.50	1.50	56.0	2.205	1.25	13.0	1 1/4	MKM 4589	M12 x 60	G40	2.7
		6510-20-20DM							M12x1.75					
<b>40</b>	<b>1 1/2</b>	6509-24-24DM	3.75	1.88	1.75	65.0	2.559	1.50	18.0	1 1/2	MKM 5509	M16 x 70	G50	5.3
		6510-24-24DM							M16x2					
<b>50</b>	<b>2</b>	6509-32-32DM	4.00	2.00	1.75	73.0	2.874	1.94	18.0	2	MKM 5521	M16 x 70	G60	5.6
		6510-32-32DM							M16x2					
<b>65</b>	<b>2 1/2</b>	6509-40-40DM	5.00	2.50	2.00	92.0	3.622	2.44	22.0	2 1/2	MKM 4592	M20 x 80	G75	9.8
		6510-40-40DM							M20x2.5					
<b>80</b>	<b>3</b>	6509-48-48DM	5.50	2.75	2.25	103.0	4.055	2.80	24.0	3	MKM 4593	M22 x 90	G85	12.6
		6510-48-48DM							M22x2.5					

① Order Separately