

NPTF THREADED IN-LINE FLANGES

JIS B 2291 BOLT PATTERN (210K)										TYPE SH(A & B)				
FLANGE SIZE	PIPE SIZE	PART NUMBER	A	B	C	Emm	E	F	Gmm Jmm	K NPTF	MOUNTING KIT®			WT
											PART NO.	SCREW SIZE	O-RING	
15	1/2	1507-08-08M	2.50	1.25	1.25	40.0	1.574	.63	11.0	1/2	MKM 5507	M10 x 50	G25	1.9
		1508-08-08M							M10x1.5					
20	3/4	1507-12-12M	2.75	1.38	1.25	45.0	1.772	.75	11.0	3/4	MKM 5508	M10 x 50	G30	2.3
		1508-12-12M							M10x1.5					
25	1	1507-16-16M	3.25	1.62	1.50	53.0	2.086	1.00	13.0	1	MKM 4588	M12 x 60	G35	3.8
		1508-16-16M							M12x1.75					
32	1 1/4	1507-20-20M	3.50	1.75	1.50	63.0	2.480	1.25	13.0	1 1/4	MKM 4589	M12 x 60	G40	4.2
		1508-20-20M							M12x1.75					
40	1 1/2	1507-24-24M	4.00	2.00	1.75	70.0	2.756	1.50	18.0	1 1/2	MKM 5509	M16 x 70	G50	6.1
		1508-24-24M							M16x2					
50	2	1507-32-32M	4.50	2.25	1.75	80.0	3.150	1.94	18.0	2	MKM 5521	M16 x 70	G60	7.3
		1508-32-32M							M16x2					
65	2 1/2	1507-40-40M	5.50	2.75	2.00	100.0	3.937	2.44	22.0	2 1/2	MKM 4592	M20 x 80	G75	12.8
		1508-40-40M							M20x2.5					
80	3	1507-48-48M	6.25	3.12	2.25	112.0	4.409	2.80	24.0	3	MKM 4593	M22 x 90	G85	17.9
		1508-48-48M							M22x2.5					

MATERIAL:
Low Carbon Steel®

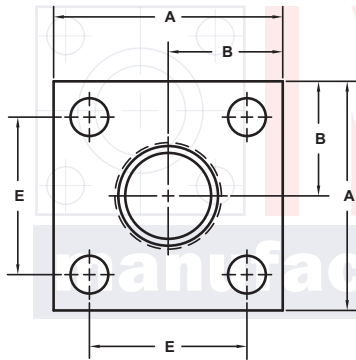
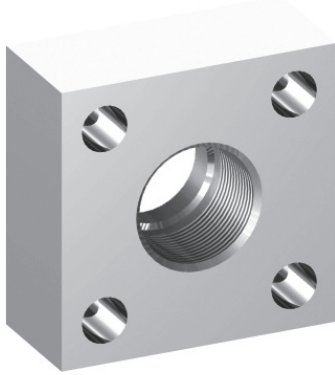

O-Ring Style

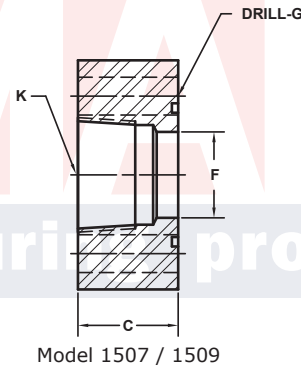

Companion Style (Flat Face)

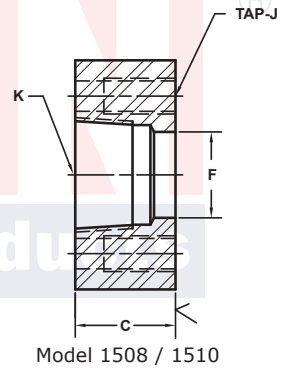

3181 TRI-PARK DR. GRAND BLANC, MI 48439 800-521-7918 810-953-1380 FAX 810-953-1385 INFO@MAINMFG.COM

JIS B 2291 BOLT PATTERN (210K)										TYPE SS(A & B)				
FLANGE SIZE	PIPE SIZE	PART NUMBER	A	B	C	Emm	E	F	Gmm Jmm	K NPTF	MOUNTING KIT®			WT
											PART NO.	SCREW SIZE	O-RING	
15	1/2	1509-08-08M	2.25	1.12	1.25	36.0	1.417	.63	11.0	1/2	MKM 5507	M10 x 50	G25	1.4
		1510-08-08M							M10x1.5					
20	3/4	1509-12-12M	2.25	1.12	1.25	40.0	1.574	.75	11.0	3/4	MKM 5508	M10 x 50	G30	1.4
		1510-12-12M							M10x1.5					
25	1	1509-16-16M	2.75	1.38	1.50	48.0	1.890	1.00	13.0	1	MKM 4588	M12 x 60	G35	2.5
		1510-16-16M							M12x1.75					
32	1 1/4	1509-20-20M	3.00	1.50	1.50	56.0	2.205	1.25	13.0	1 1/4	MKM 4589	M12 x 60	G40	2.7
		1510-20-20M							M12x1.75					
40	1 1/2	1509-24-24M	3.75	1.88	1.75	65.0	2.559	1.50	18.0	1 1/2	MKM 5509	M16 x 70	G50	5.3
		1510-24-24M							M16x2					
50	2	1509-32-32M	4.00	2.00	1.75	73.0	2.874	1.94	18.0	2	MKM 5521	M16 x 70	G60	5.6
		1510-32-32M							M16x2					
65	2 1/2	1509-40-40M	5.00	2.50	2.00	92.0	3.622	2.44	22.0	2 1/2	MKM 4592	M20 x 80	G75	9.8
		1510-40-40M							M20x2.5					
80	3	1509-48-48M	5.50	2.75	2.25	103.0	4.055	2.80	24.0	3	MKM 4593	M22 x 90	G85	12.6
		1510-48-48M							M22x2.5					

① Order Separately

⑤ May Contain Lead