

BUTT WELD ELBOW FLANGES

For Schedule 160 Pipe ⑥

3000 SERIES SQUARE BOLT PATTERN

FLANGE SIZE	PIPE SIZE	PART NUMBER	A	B	C	D	E	F	G		H	K	MOUNTING KIT®			WT
									J				PART NO.	SCREW SIZE	O-RING	
1/2	1/2	6427-08-08D	2.75	2.25	1.50	.719	1.438	.47	.41	.38	.88		MK 532	3/8-16 x 2 1/4	216	2.0
		3/8-16														
3/4	3/4	6427-12-12D	2.75	2.25	1.50	.719	1.438	.61	.41	.38	1.12		MK 532	3/8-16 x 2 1/4	216	1.9
		3/8-16														
1	1	6427-16-16D	3.50	3.00	2.00	1.000	2.000	.81	.53	.38	1.38		MK 533	1/2-13 x 2 3/4	222	4.4
		1/2-13														
1 1/4	1 1/4	6427-20-20D	3.50	3.00	2.25	1.000	2.000	1.16	.53	.38	1.75		MK 534	1/2-13 x 3	222	4.7
		1/2-13														
1 1/2	1 1/2	6427-24-24D	4.62	4.00	3.00	1.375	2.750	1.34	.66	.50	2.00		MK 535	5/8-11 x 4	228	11.5
		5/8-11														
2	2	6427-32-32D	4.62	4.00	3.50	1.375	2.750	1.69	.66	.50	2.50		MK 1598	5/8-11 x 4 1/2	228	12.4
		5/8-11														
2 1/2	2 1/2	6427-40-40D	6.25	5.50	4.00	1.875	3.750	2.12	.94	.75	3.00		MK 536	7/8-9 x 5 1/2	236	26.3
		7/8-9														
3	3	6427-48-48D	6.25	5.50	4.50	1.875	3.750	2.62	.94	.75	3.50		MK 537	7/8-9 x 6	236	28.6
		7/8-9														
3 1/2	3 1/2	6427-56-56D	7.00	6.00	5.50	2.125	4.250	3.00	.94	1.00	4.00		MK 3528	7/8-9 x 7	240	42.3
		7/8-9														
4	4	6427-64-64D	8.00	7.00	6.00	2.500	5.000	3.44	1.06	1.00	4.50		MK 2573	1-8 x 7 1/2	347	61.8
		1-8														
5	5	6427-80-80D	9.00	8.00	7.00	3.000	6.000	4.31	1.06	1.00	5.62		MK 3522	1-8 x 8 1/2	355	89.6
		1-8														

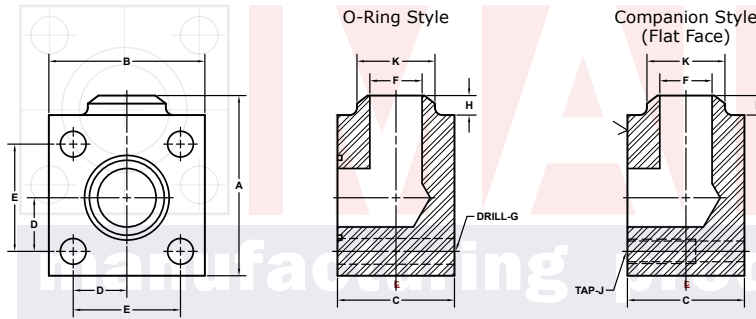

MATERIAL:
316L Stainless

MOUNTING KITS listed contain carbon steel bolts and Buna N O-Ring. To specify stainless Grade 18-8 bolts, add an SS at the end of the kit number (MK 501SS).

Please note that using stainless steel bolts may reduce the pressure rating of the assembly.

Model 6427 / 6429 Model 6428 / 6430
3181 TRI-PARK DR. GRAND BLANC, MI 48439 800-521-7918 810-953-1380 FAX 810-953-1385 INFO@MAINMFG.COM

6000 SERIES SQUARE BOLT PATTERN

FLANGE SIZE	PIPE SIZE	PART NUMBER	A	B	C	D	E	F	G		H	K	MOUNTING KIT®			WT
									J				PART NO.	SCREW SIZE	O-RING	
1/2	1/2	6429-08-08D	2.75	2.25	1.50	.719	1.438	.47	.41	.38	.88		MK 5515	3/8-16 x 2 1/4	210	2.0
		3/8-16														
3/4	3/4	6429-12-12D	3.00	2.50	1.75	.875	1.750	.61	.41	.38	1.12		MK 542	3/8-16 x 2 1/2	214	2.9
		3/8-16														
1	1	6429-16-16D	3.50	3.00	2.25	1.000	2.000	.81	.53	.38	1.38		MK 5516	1/2-13 x 2 3/4	219	5.1
		1/2-13														
1 1/4	1 1/4	6429-20-20D	4.62	4.00	3.00	1.375	2.750	1.16	.66	.38	1.75		MK 5517	5/8-11 x 4	222	12.3
		5/8-11														
1 1/2	1 1/4	6429-24-20D	4.62	4.00	3.00	1.375	2.750	1.16	.66	.50	1.75		MK 553	5/8-11 x 4	225	11.8
		5/8-11														
1 1/2	1 1/2	6429-24-24D	4.62	4.00	3.00	1.375	2.750	1.34	.66	.50	2.00		MK 553	5/8-11 x 4	225	11.6
		5/8-11														
2	1 1/2	6429-32-24D	5.50	5.00	4.00	1.750	3.500	1.34	.78	.50	2.00		MK 4580	3/4-10 x 5 1/2	228	24.1
		3/4-10														
2	2	6429-32-32D	5.50	5.00	4.00	1.750	3.500	1.69	.78	.50	2.50		MK 4580	3/4-10 x 5 1/2	228	23.6
		3/4-10														
2 1/2	2	6429-40-32D	6.25	5.50	4.50	1.875	3.750	1.69	.94	.75	2.50		MK 2557	7/8-9 x 6	232	31.4
		7/8-9														
2 1/2	2 1/2	6429-40-40D	6.25	5.50	4.50	1.875	3.750	2.12	.94	.75	3.00		MK 2557	7/8-9 x 6	232	30.6
		7/8-9														
3	3	6429-48-48D	7.50	7.00	5.00	2.375	4.750	2.62	1.06	.75	3.50		MK 5518	1-8 x 7	236	57.0
		1-8														

① Order Separately

⑥ Schedules 40, 80 and XXS also Stocked. Other Pipe and Tube Sizes are Available