

BUTT WELD IN-LINE FLANGES

For Schedule 160 Pipe ⑥

3000 SERIES SQUARE BOLT PATTERN

FLANGE SIZE	PIPE SIZE	PART NUMBER	A	B	C	D	E	F	G		H	K	MOUNTING KIT®			WT
									J				PART NO.	SCREW SIZE	O-RING	
3/4	3/4	6403-12-12D	2.25	1.12	1.25	.719	1.438	.61	.41	.38	1.12	MK 528	3/8-16 x 1 3/4	216	1.1	
		3/8-16														
1	1	6403-16-16D	3.00	1.50	1.25	1.000	2.000	.81	.53	.38	1.38	MK 529	1/2-13 x 1 3/4	222	1.6	
		1/2-13														
1 1/4	1 1/4	6403-20-20D	3.00	1.50	1.25	1.000	2.000	1.16	.53	.38	1.75	MK 529	1/2-13 x 1 3/4	222	1.5	
		1/2-13														
1 1/2	1 1/2	6403-24-24D	4.00	2.00	1.50	1.375	2.750	1.34	.66	.50	2.00	MK 581	5/8-11 x 2	228	3.3	
		5/8-11														
2	2	6403-32-32D	4.00	2.00	1.50	1.375	2.750	1.69	.66	.50	2.50	MK 581	5/8-11 x 2	228	3.2	
		5/8-11														
2 1/2	2 1/2	6403-40-40D	5.50	2.75	1.75	1.875	3.750	2.12	.94	.50	3.00	MK 1519	7/8-9 x 2 1/2	236	7.4	
		7/8-9														
3	3	6403-48-48D	5.50	2.75	1.75	1.875	3.750	2.62	.94	.50	3.50	MK 1519	7/8-9 x 2 1/2	236	7.0	
		7/8-9														
3 1/2	3 1/2	6403-56-56D	6.00	3.00	1.75	2.125	4.250	3.00	.94	.50	4.00	MK 1577	7/8-9 x 2 1/2	240	10.2	
		7/8-9														
4	4	6403-64-64D	7.00	3.50	2.00	2.500	5.000	3.44	1.06	.50	4.50	MK 1578	1-8 x 3	347	16.5	
		1-8														
5	5	6403-80-80D	8.00	4.00	2.50	3.000	6.000	4.31	1.06	.50	5.62	MK 1579	1-8 x 3 1/2	355	27.0	
		1-8														
6	6	6403-96-96D	10.00	5.00	2.50	3.500	7.000	5.19	1.31	.50	6.75	MK 5533	1 1/4-7 x 4	362	38.8	
		1 1/4-7														

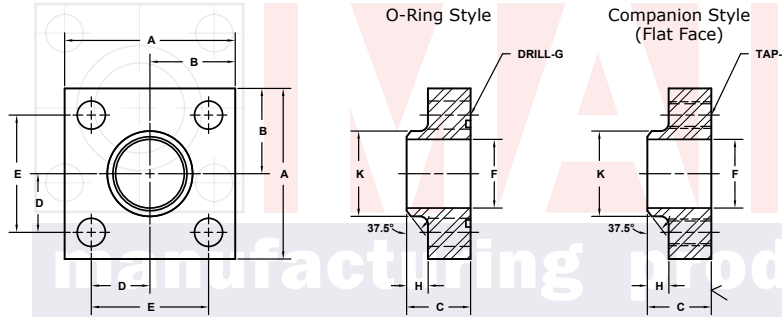
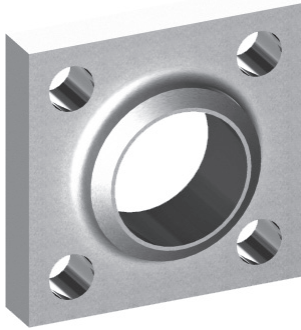

MATERIAL:
316L Stainless

MOUNTING KITS listed contain carbon steel bolts and Buna N O-Ring. To specify stainless Grade 18-8 bolts, add an SS at the end of the kit number (MK 501SS).

Please note that using stainless steel bolts may reduce the pressure rating of the assembly.

Model 6403 / 6405 Model 6404 / 6406
3181 TRI-PARK DR. GRAND BLANC, MI 48439 800-521-7918 810-953-1380 FAX 810-953-1385 INFO@MAINMFG.COM

6000 SERIES SQUARE BOLT PATTERN

FLANGE SIZE	PIPE SIZE	PART NUMBER	A	B	C	D	E	F	G		H	K	MOUNTING KIT®			WT
									J				PART NO.	SCREW SIZE	O-RING	
1/2	1/2	6405-08-08D	2.25	1.12	1.50	.719	1.438	.47	.41	.50	.88	MK 2501	3/8-16 x 1 3/4	210	1.5	
		3/8-16														
3/4	3/4	6405-12-12D	2.50	1.25	1.50	.875	1.750	.61	.41	.50	1.12	MK 2502	3/8-16 x 1 3/4	214	1.7	
		3/8-16														
1	1	6405-16-16D	3.00	1.50	1.50	1.000	2.000	.81	.53	.50	1.38	MK 2503	1/2-13 x 2	219	2.5	
		1/2-13														
1 1/4	1 1/4	6405-20-20D	4.00	2.00	1.75	1.375	2.750	1.16	.66	.50	1.75	MK 2504	5/8-11 x 2 1/2	222	5.3	
		5/8-11														
1 1/2	1 1/2	6405-24-24D	4.00	2.00	2.00	1.375	2.750	1.34	.66	.50	2.00	MK 2505	5/8-11 x 2 3/4	225	6.2	
		5/8-11														
2	2	6405-32-32D	5.00	2.50	2.25	1.750	3.500	1.69	.78	.50	2.50	MK 2506	3/4-10 x 3 1/2	228	11.0	
		3/4-10														
2 1/2	2 1/2	6405-40-40D	5.50	2.75	2.25	1.875	3.750	2.12	.94	.50	3.00	MK 2507	7/8-9 x 3 1/2	232	12.8	
		7/8-9														
3	3	6405-48-48D	7.00	3.50	2.50	2.375	4.750	2.62	1.06	.50	3.50	MK 2508	1-8 x 4	236	23.8	
		1-8														
3 1/2	3 1/2	6405-56-56D	8.00	4.00	3.50	2.750	5.500	3.00	1.31	1.00	4.00	MK 2509	1 1/4-7 x 5	342	38.5	
		1 1/4-7														
4	4	6405-64-64D	8.50	4.25	3.50	3.000	6.000	3.44	1.31	1.00	4.50	MK 2510	1 1/4-7 x 5	346	43.0	
		1 1/4-7														
5	5	6405-80-80D	10.00	5.00	4.00	3.625	7.250	4.31	1.56	1.00	5.62	MK 2511	1 1/2-6 x 6	353	69.0	
		1 1/2-6														

① Order Separately

⑥ Schedules 40, 80 and XXS also Stocked. Other Pipe and Tube Sizes are Available