

BSPT THREADED ELBOW FLANGES

SAE BOLT PATTERN										61 SERIES					
FLANGE SIZE	PIPE SIZE	PART NUMBER	A	B	C	D	E	F	G J	H	K BSPT	MOUNTING KIT®			WT
												PART NO.	BOLT SIZE	O-RING	
1/2	1/2	6363-08-08D	2.00	2.12	1.44	1.500	.688	.50	.34	.75	1/2	MK 541	5/16-18 x 2	210	1.5
		6364-08-08D							5/16-18						
3/4	3/4	6363-12-12D	2.50	2.62	1.70	1.875	.875	.75	.41	.88	3/4	MK 542	3/8-16 x 2 1/2	214	2.6
		6364-12-12D							3/8-16						
1	1	6363-16-16D	3.00	2.82	1.94	2.062	1.031	1.00	.41	1.00	1	MK 543	3/8-16 x 2 3/4	219	3.5
		6364-16-16D							3/8-16						
1 1/4	1	6363-20-16D	3.50	3.19	2.40	2.312	1.188	1.25	.47	1.25	1	MK 578	7/16-14 x 3 1/4	222	6.5
		6364-20-16D							7/16-14						
1 1/4	1 1/4	6363-20-20D	3.50	3.19	2.40	2.312	1.188	1.25	.47	1.25	1 1/4	MK 578	7/16-14 x 3 1/4	222	6.0
		6364-20-20D							7/16-14						
1 1/2	1 1/4	6363-24-20D	4.00	3.75	2.90	2.750	1.406	1.50	.53	1.38	1 1/4	MK 545	1/2-13 x 4	225	10.0
		6364-24-20D							1/2-13						
1 1/2	1 1/2	6363-24-24D	4.00	3.75	2.90	2.750	1.406	1.50	.53	1.38	1 1/2	MK 545	1/2-13 x 4	225	9.5
		6364-24-24D							1/2-13						
2	1 1/2	6363-32-24D	4.50	4.00	2.96	3.062	1.688	1.94	.53	1.62	1 1/2	MK 558	1/2-13 x 4	228	10.9
		6364-32-24D							1/2-13						
2	2	6363-32-32D	4.50	4.00	2.96	3.062	1.688	1.94	.53	1.62	2	MK 558	1/2-13 x 4	228	10.5
		6364-32-32D							1/2-13						
2 1/2 ^②	2 1/2	6363-40-40D	5.00	4.50	3.96	3.500	2.000	2.44	.53	2.00	2 1/2	MK 547	1/2-13 x 5	232	17.5
		6364-40-40D							1/2-13						
3 ^③	3	6363-48-48D	6.00	5.31	4.46	4.188	2.438	2.94	.66	2.25	3	MK 2532	5/8-11 x 5 1/2	237	26.5
		6364-48-48D							5/8-11						

MOUNTING KITS listed contain carbon steel bolts and Buna N O-Ring. To specify stainless Grade 18-8 bolts, add an SS at the end of the kit number (MK 501SS).

Please note that using stainless steel bolts may reduce the pressure rating of the assembly.

**MATERIAL:
316L Stainless**

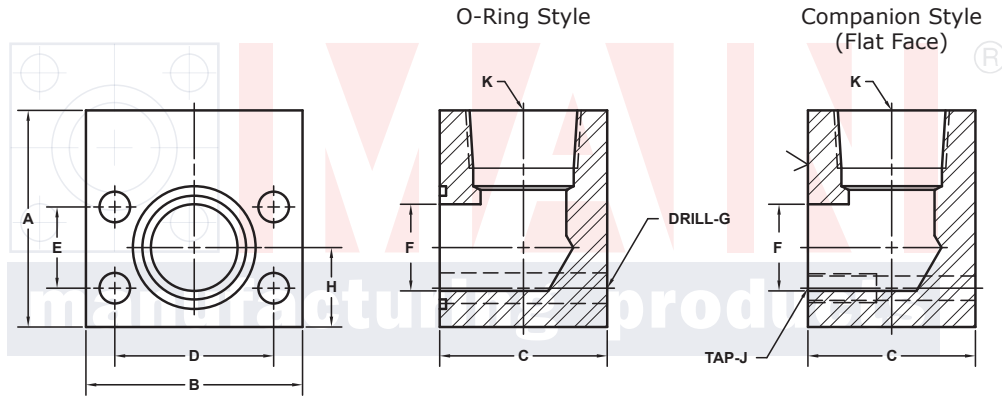

Model 6363 / 6365

Model 6364 / 6366

3181 TRI-PARK DR. GRAND BLANC, MI 48439 800-521-7918 810-953-1380 FAX 810-953-1385 INFO@MAINMFG.COM

SAE BOLT PATTERN										62 SERIES					
FLANGE SIZE	PIPE SIZE	PART NUMBER	A	B	C	D	E	F	G J	H	K BSPT	MOUNTING KIT®			WT
												PART NO.	BOLT SIZE	O-RING	
1/2	1/2	6365-08-08D	2.00	2.22	1.46	1.594	.718	.50	.34	.88	1/2	MK 541	5/16-18 x 2	210	1.6
		6366-08-08D							5/16-18						
3/4	3/4	6365-12-12D	2.50	2.81	1.70	2.000	.937	.75	.41	1.00	3/4	MK 542	3/8-16 x 2 1/2	214	2.8
		6366-12-12D							3/8-16						
1	1	6365-16-16D	3.00	3.19	1.96	2.250	1.093	1.00	.47	1.12	1	MK 551	7/16-14 x 2 3/4	219	4.4
		6366-16-16D							7/16-14						
1 1/4	1 1/4	6365-20-20D	4.00	3.75	2.44	2.625	1.250	1.25	.53	1.38	1 1/4	MK 552	1/2-13 x 3 1/4	222	8.2
		6366-20-20D							1/2-13						
1 1/2	1 1/2	6365-24-24D	4.00	4.50	2.96	3.125	1.437	1.50	.66	1.62	1 1/2	MK 553	5/8-11 x 4	225	12.0
		6366-24-24D							5/8-11						
2	2	6365-32-32D	5.00	5.25	3.46	3.812	1.750	1.94	.78	2.00	2	MK 554	3/4-10 x 4 1/2	228	20.0
		6366-32-32D							3/4-10						
2 1/2	2 1/2	6365-40-40D	6.00	6.88	4.00	4.875	2.312	2.44	.94	2.50	2 1/2	MK 555	7/8-9 x 5 1/2	232	37.9
		6366-40-40D							7/8-9						
3	3	6365-48-48D	7.00	8.50	5.00	6.000	2.812	2.94	1.19	3.00	3	MK 756	1 1/8-7 x 7	237	64.0
		6366-48-48D							1 1/8-7						

① Order Separately

② 2500 PSI Max ③ 2000 PSI Max