

BSPT THREADED IN-LINE FLANGES

SAE J518 61 SERIES / ISO6162-1 PATTERN

FLANGE SIZE	PIPE SIZE	PART NUMBER	A	B	C	D	E	F	Gmm	K BSPT	MOUNTING KIT®			WT
									Jmm		PART NO.	SCREW SIZE	O-RING	
1/2	1/2	1355-08-08M8	1.50	2.12	1.25	1.500	.688	.50	8.5	1/2	MKM 519	M8 x 45	210	.8
		M8x1.25							-----		---			
3/4	3/4	1355-12-12M10	1.75	2.62	1.25	1.875	.875	.75	10.5	3/4	MKM 520	M10 x 45	214	1.2
		M10x1.5							-----		---			
1	1	1355-12-16M10	2.00	2.82	1.50	2.062	1.031	1.00	10.5	1	MKM 521	M10 x 50	219	1.7
		M10x1.5							-----		---			
1 1/4	1 1/4	1355-20-20M10†	2.50	3.19	1.50	2.312	1.188	1.25	10.5	1 1/4	MKM 3526	M10 x 50	222	2.3
		M10x1.5							-----		---			
1 1/2	1 1/2	1355-24-24M12‡	2.75	3.75	1.75	2.750	1.406	1.50	13.0	1 1/2	MKM 2565	M12 x 60	225	3.6
		M12x1.75							-----		---			
2	1 1/2	1355-32-24M12‡	3.25	4.00	1.75	3.062	1.688	1.74	13.0	1 1/2	MKM 2566	M12 x 60	228	4.9
		M12x1.75							-----		---			
2	2	1355-32-32M12‡	3.25	4.00	1.75	3.062	1.688	1.94	13.0	2	MKM 2566	M12 x 60	228	4.2
		M12x1.75							-----		---			
2 1/2 ^②	2 1/2	1355-40-40M12‡	4.00	4.50	2.00	3.500	2.00	2.44	13.0	2 1/2	MKM 2574	M12 x 70	232	6.5
		M12x1.75							-----		---			
3 ^③	3	1355-48-48M16	4.50	5.50	2.25	4.188	2.438	2.94	17.0	3	MKM 1516	M16 x 80	237	9.8
		M16x2							-----		---			
3 1/2 ^④	3 1/2	1355-56-56M16	5.00	6.00	2.25	4.750	2.750	3.44	17.0	3 1/2	MKM 2576	M16 x 90	241	11.0
		M16x2							-----		---			
4 ^④	4	1355-64-64M16	5.50	6.50	2.50	5.125	3.062	3.94	17.0	4	MKM 2545	M16 x 90	245	14.5
		M16x2							-----		---			

MATERIAL:
Low Carbon Steel^⑤

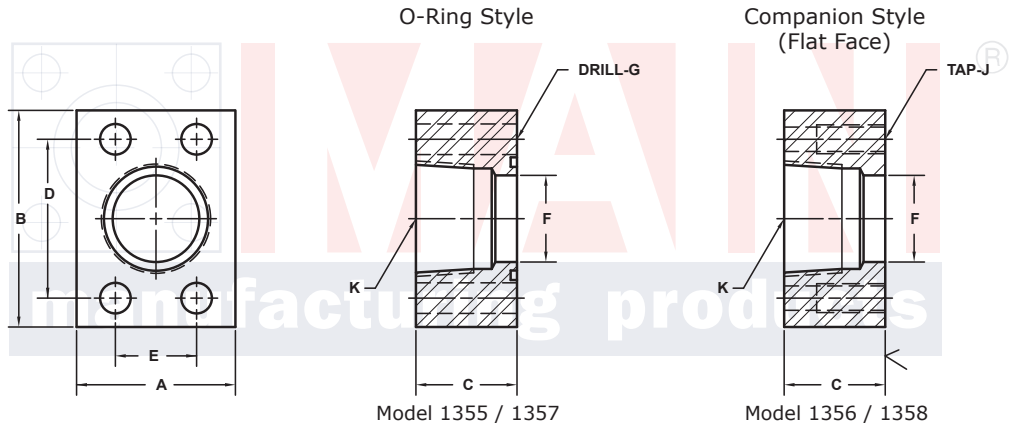
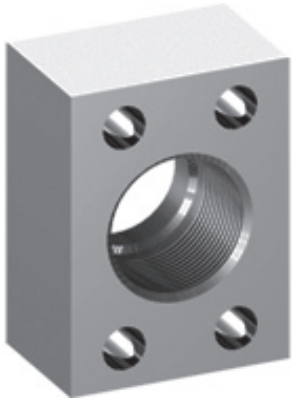

3181 TRI-PARK DR. GRAND BLANC, MI 48439 800-521-7918 810-953-1380 FAX 810-953-1385 INFO@MAINMFG.COM

SAE J518 62 SERIES / ISO6162-2 PATTERN

FLANGE SIZE	PIPE SIZE	PART NUMBER	A	B	C	D	E	F	Gmm	K BSPT	MOUNTING KIT®			WT
									Jmm		PART NO.	SCREW SIZE	O-RING	
1/2	1/2	1357-08-08M8	1.75	2.22	1.25	1.594	.718	.50	8.5	1/2	MKM 519	M8 x 45	210	1.1
		M8x1.25							-----		---			
3/4	3/4	1357-12-12M10	2.00	2.81	1.25	2.000	.937	.75	10.5	3/4	MKM 520	M10 x 45	214	1.5
		M10x1.5							-----		---			
1	1	1357-16-16M10	2.25	3.19	1.50	2.250	1.093	1.00	12.5	1	MKM 525	M12 x 55	219	2.3
		M12x1.75							-----		---			
1 1/4	1 1/4	1357-20-20M12‡	3.00	3.75	1.50	2.625	1.250	1.25	13.0	1 1/4	MKM 522	M12 x 55	222	3.7
		M12x1.75							-----		---			
1 1/2	1 1/2	1357-24-24M16	3.25	4.50	1.75	3.125	1.437	1.50	17.0	1 1/2	MKM 527	M16 x 65	225	5.6
		M16x2							-----		---			
2	2	1357-32-32M20	4.00	5.25	1.75	3.812	1.750	1.94	21.0	2	MKM 516	M20x 70	228	7.8
		M20x2.5							-----		---			
2 1/2	2 1/2	1357-40-40M24	5.00	6.88	2.00	4.875	2.312	2.44	25.5	2 1/2	MKM 517	M24x 80	232	15.1
		M24x3							-----		---			
3	3	1357-48-48M30	6.00	8.50	2.50	6.000	2.812	2.94	32.0	3	MKM 518	M30 x 110	237	27.5
		M30x3.5							-----		---			

① Order Separately

② 2500 PSI Max

③ 2000 PSI Max

④ 500 PSI Max

⑤ May Contain Lead