

BUTT WELD IN-LINE FLANGES (Pg 1/2)

For Schedule 160 Pipe ©

FLANGE SIZE	PIPE SIZE	SAE BOLT PATTERN							61 SERIES						WT
		PART NUMBER	A	B	C	D	E	F	G	H	K	MOUNTING KIT®			
												J	PART NO.	SCREW SIZE	
1/2	1/2	6117-08-08D	1.50	2.12	1.25	1.500	.688	.47	.34	.38	.88	MK 512	5/16-18 x 1 1/2	210	.7
		6118-08-08D							5/16-18						
3/4	1/2	6117-12-08D	1.75	2.62	1.25	1.875	.875	.47	.41	.38	.88	MK 1525	3/8-16 x 1 1/2	214	1.1
		6118-12-08D							3/8-16						
3/4	3/4	6117-12-12D	1.75	2.62	1.25	1.875	.875	.61	.41	.38	1.12	MK 1525	3/8-16 x 1 1/2	214	1.0
		6118-12-12D							3/8-16						
1	3/4	6117-16-12D	2.00	2.82	1.25	2.062	1.031	.61	.41	.38	1.12	MK 1542	3/8-16 x 1 1/2	219	1.3
		6118-16-12D							3/8-16						
1	1	6117-16-16D	2.00	2.82	1.25	2.062	1.031	.81	.41	.38	1.38	MK 1542	3/8-16 x 1 1/2	219	1.2
		6118-16-16D							3/8-16						
1 1/4	1	6117-20-16D	2.50	3.19	1.25	2.312	1.188	.81	.47	.38	1.38	MK 1527	7/16-14 x 1 1/2	222	1.8
		6118-20-16D							7/16-14						
1 1/4	1 1/4	6117-20-20D	2.50	3.19	1.25	2.312	1.188	1.16	.47	.38	1.75	MK 1527	7/16-14 x 1 1/2	222	1.6
		6118-20-20D							7/16-14						
1 1/4	1 1/2	-----	2.50	3.19	1.50	2.312	1.188	1.25	----	.50	2.00	-----	-----	---	2.1
		6118-20-24D							7/16-14						
1 1/2	1 1/4	6117-24-20D	2.75	3.75	1.50	2.750	1.406	1.16	.53	.50	1.75	MK 1547	1/2-13 x 1 3/4	225	2.6
		6118-24-20D							1/2-13						
1 1/2	1 1/2	6117-24-24D	2.75	3.75	1.50	2.750	1.406	1.34	.53	.50	2.00	MK 1547	1/2-13 x 1 3/4	225	2.3
		6118-24-24D							1/2-13						
1 1/2	2	-----	3.50	3.75	2.25	2.750	1.406	1.50	----	.50	2.50	-----	-----	---	5.8
		6118-24-32D							1/2-13						

MATERIAL:
316L Stainless

MOUNTING KITS listed contain carbon steel bolts and Buna N O-Ring. To specify stainless Grade 18-8 bolts, add an SS at the end of the kit number (MK 501SS).

Please note that using stainless steel bolts may reduce the pressure rating of the assembly.

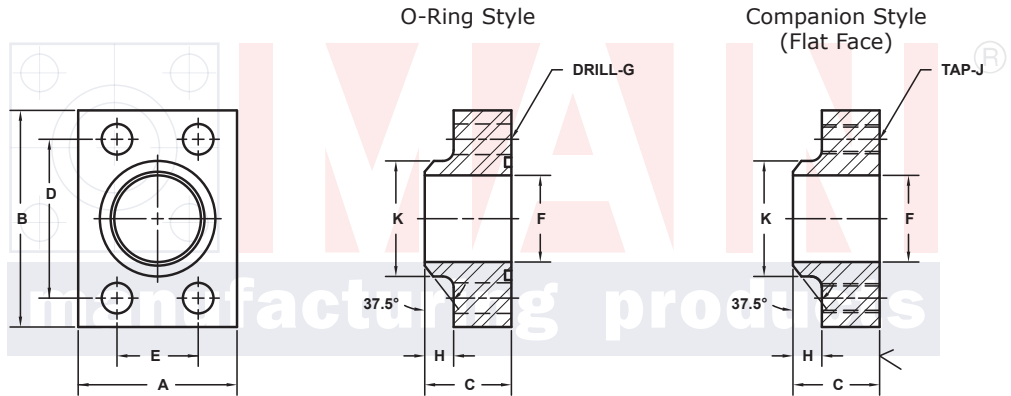

Model 6117 / 6119

Model 6118 / 6120

3181 TRI-PARK DR. GRAND BLANC, MI 48439 800-521-7918 810-953-1380 FAX 810-953-1385 INFO@MAINMFG.COM

FLANGE SIZE	PIPE SIZE	SAE BOLT PATTERN							62 SERIES						WT
		PART NUMBER	A	B	C	D	E	F	G	H	K	MOUNTING KIT®			
												J	PART NO.	SCREW SIZE	
1/2	1/2	6119-08-08D	1.75	2.22	1.25	1.594	.718	.47	.34	.38	.88	MK 512	5/16-18 x 1 1/2	210	.8
		6120-08-08D							5/16-18						
3/4	1/2	6119-12-08D	2.00	2.81	1.25	2.000	.937	.47	.41	.38	.88	MK 1525	3/8-16 x 1 1/2	214	1.3
		6120-12-08D							3/8-16						
3/4	3/4	6119-12-12D	2.00	2.81	1.25	2.000	.937	.61	.41	.38	1.12	MK 1525	3/8-16 x 1 1/2	214	1.3
		6120-12-12D							3/8-16						
1	3/4	6119-16-12D	2.25	3.19	1.25	2.250	1.093	.61	.47	.38	1.12	MK 513	7/16-14 x 1 3/4	219	1.7
		6120-16-12D							7/16-14						
1	1	6119-16-16D	2.25	3.19	1.25	2.250	1.093	.81	.47	.38	1.38	MK 513	7/16-14 x 1 3/4	219	1.5
		6120-16-16D							7/16-14						
1 1/4	1	6119-20-16D	2.75	3.75	1.25	2.625	1.250	.81	.53	.38	1.38	MK 529	1/2-13 x 1 3/4	222	2.4
		6120-20-16D							1/2-13						
1 1/4	1 1/4	6119-20-20D	2.75	3.75	1.25	2.625	1.250	1.16	.53	.38	1.75	MK 529	1/2-13 x 1 3/4	222	2.1
		6120-20-20D							1/2-13						
1 1/4	1 1/2	-----	3.00	3.75	1.50	2.625	1.250	1.25	----	.50	2.00	-----	-----	---	3.1
		6120-20-24D							1/2-13						

① Order Separately

⑥ Other Pipe and Tube Sizes are Available

BUTT WELD IN-LINE FLANGES (Pg 2/2)

For Schedule 160 Pipe ⑥

SAE BOLT PATTERN										61 SERIES					
FLANGE SIZE	PIPE SIZE	PART NUMBER	A	B	C	D	E	F	G J	H	K	MOUNTING KIT①			WT
												PART NO.	SCREW SIZE	O-RING	
2	1 1/4	6117-32-20D	3.25	4.00	1.50	3.062	1.688	1.16	.53	.50	1.75	MK 582	1/2-13 x 1 3/4	228	3.4
		6118-32-20D							1/2-13						
2	1 1/2	6117-32-24D	3.25	4.00	1.50	3.062	1.688	1.34	.53	.50	2.00	MK 582	1/2-13 x 1 3/4	228	3.3
		6118-32-24D							1/2-13						
2	2	6117-32-32D	3.25	4.00	1.50	3.062	1.688	1.69	.53	.50	2.50	MK 582	1/2-13 x 1 3/4	228	2.8
		6118-32-32D							1/2-13						
2 1/2 ^②	2	6117-40-32D	4.00	4.50	1.75	3.500	2.000	1.69	.53	.50	2.50	MK 561	1/2-13 x 2	232	5.7
		6118-40-32D							1/2-13						
2 1/2 ^②	2 1/2	6117-40-40D	4.00	4.50	1.75	3.500	2.000	2.12	.53	.50	3.00	MK 561	1/2-13 x 2	232	4.8
		6118-40-40D							1/2-13						
3 ^③	2 1/2	6117-48-40D	4.50	5.31	2.00	4.188	2.438	2.12	.66	.50	3.00	MK 585	5/8-11 x 2 1/2	237	8.7
		6118-48-40D							5/8-11						
3 ^③	3	6117-48-48D	4.50	5.31	2.00	4.188	2.438	2.62	.66	.50	3.50	MK 585	5/8-11 x 2 1/2	237	7.2
		6118-48-48D							5/8-11						
3 1/2 ^④	3	6117-56-48D	5.00	6.00	1.50	4.750	2.750	2.62	.66	.50	3.50	MK 1571	5/8-11 x 2	241	7.2
		6118-56-48D							5/8-11						
3 1/2 ^④	3 1/2	6117-56-56D	5.00	6.00	1.50	4.750	2.750	3.00	.66	.50	4.00	MK 1571	5/8-11 x 2	241	5.9
		6118-56-56D							5/8-11						
4 ^④	3	6117-64-48D	5.50	6.38	1.50	5.125	3.062	2.62	.66	.50	3.50	MK 1572	5/8-11 x 2	245	8.6
		6118-64-48D							5/8-11						
4 ^④	4	6117-64-64D	5.50	6.38	1.50	5.125	3.062	3.44	.66	.50	4.50	MK 1572	5/8-11 x 2	245	6.7
		6118-64-64D							5/8-11						

MOUNTING KITS listed contain carbon steel bolts and Buna N O-Ring. To specify stainless Grade 18-8 bolts, add an SS at the end of the kit number (MK 501SS).

Please note that using stainless steel bolts may reduce the pressure rating of the assembly.

MATERIAL:
316L Stainless

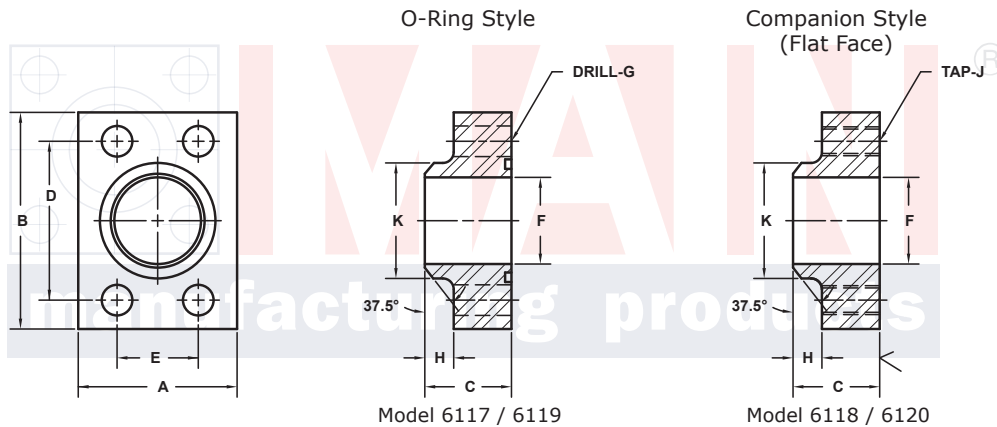

3181 TRI-PARK DR. GRAND BLANC, MI 48439 800-521-7918 810-953-1380 FAX 810-953-1385 INFO@MAINMFG.COM

SAE BOLT PATTERN										62 SERIES					
FLANGE SIZE	PIPE SIZE	PART NUMBER	A	B	C	D	E	F	G J	H	K	MOUNTING KIT①			WT
												PART NO.	SCREW SIZE	O-RING	
1 1/2	1 1/4	6119-24-20D	3.25	4.50	1.50	3.125	1.437	1.16	.66	.50	1.75	MK 562	5/8-11 x 2	225	3.8
		6120-24-20D							5/8-11						
1 1/2	1 1/2	6119-24-24D	3.25	4.50	1.50	3.125	1.437	1.34	.66	.50	2.00	MK 562	5/8-11 x 2	225	3.3
		6120-24-24D							5/8-11						
1 1/2	2	-----	4.00	4.50	2.00	3.125	1.437	1.50	---	.50	2.50	-----	-----	---	6.9
		6120-24-32D							5/8-11						
2	1 1/2	6119-32-24D	4.00	5.25	1.75	3.812	1.750	1.34	.78	.50	2.00	MK 1548	3/4-10 x 2 1/2	228	6.7
		6120-32-24D							3/4-10						
2	2	6119-32-32D	4.00	5.25	1.75	3.812	1.750	1.69	.78	.50	2.50	MK 1548	3/4-10 x 2 1/2	228	5.9
		6120-32-32D							3/4-10						
2 1/2	2	6119-40-32D	5.00	6.88	2.00	4.875	2.312	1.69	.94	.50	2.50	MK 1575	7/8-9 x 2 3/4	232	13.2
		6120-40-32D							7/8-9						
2 1/2	2 1/2	6119-40-40D	5.00	6.88	2.00	4.875	2.312	2.12	.94	.50	3.00	MK 1575	7/8-9 x 2 3/4	232	12.0
		6120-40-40D							7/8-9						
3	3	6119-48-48D	6.00	8.50	2.50	6.000	2.812	2.62	1.19	.50	3.50	MK 1776	1 1/8-7 x 4	237	23.3
		6120-48-48D							1 1/8-7						

① Order Separately ② 2500 PSI Max ③ 2000 PSI Max ④ 500 PSI Max

⑥ Other Pipe and Tube Sizes are Available