

# BUTT WELD IN-LINE FLANGES (Pg 1/2)

For Schedule 160 Pipe ©

## SAE J518 61 SERIES / ISO6162-1 PATTERN

FLANGE SIZE	PIPE SIZE	PART NUMBER	A	B	C	D	E	F	Gmm		H	K	MOUNTING KIT®			WT
									Jmm				PART NO.	SCREW SIZE	O-RING	
1/2	1/2	6117-08-08DM8	1.50	2.12	1.25	1.500	.688	.47	8.5	.38	.88	MKM 512	M8 x 35	210	.7	
		M8x1.25														
3/4	1/2	6117-12-08DM10	1.75	2.62	1.25	1.875	.875	.47	10.5	.38	.88	MKM 1525	M10 x 35	214	1.1	
		M10x1.5														
3/4	3/4	6117-12-12DM10	1.75	2.62	1.25	1.875	.875	.61	10.5	.38	1.12	MKM 1525	M10 x 35	214	1.0	
		M10x1.5														
1	3/4	6117-16-12DM10	2.00	2.82	1.25	2.062	1.031	.61	10.5	.38	1.12	MKM 1542	M10 x 35	219	1.3	
		M10x1.5														
1	1	6117-16-16DM10	2.00	2.82	1.25	2.062	1.031	.81	10.5	.38	1.38	MKM 1542	M10 x 35	219	1.2	
		M10x1.5														
1 1/4	1	6117-20-16DM10†	2.50	3.19	1.25	2.312	1.188	.81	10.5	.38	1.38	MKM 4520	M10 x 35	222	1.8	
		M10x1.5														
1 1/4	1 1/4	6117-20-20DM10†	2.50	3.19	1.25	2.312	1.188	1.16	10.5	.38	1.75	MKM 4520	M10 x 35	222	1.6	
		M10x1.5														
1 1/4	1 1/2	6118-20-24DM10†	2.50	3.19	1.50	2.312	1.188	1.25	---	.50	2.00	---	---	---	2.1	
		M10x1.5														
1 1/2	1 1/4	6117-24-20DM12‡	2.75	3.75	1.50	2.750	1.406	1.16	13.0	.50	1.75	MKM 4551	M12 x 40	225	2.6	
		M12x1.75														
1 1/2	1 1/2	6117-24-24DM12‡	2.75	3.75	1.50	2.750	1.406	1.34	13.0	.50	2.00	MKM 4551	M12 x 40	225	2.3	
		M12x1.75														
1 1/2	2	6118-24-32DM12‡	3.50	3.75	2.25	2.750	1.406	1.50	---	.50	2.50	---	---	---	5.8	
		M12x1.75														

MATERIAL:  
316L Stainless

MOUNTING KITS listed contain carbon steel bolts and Buna N O-Ring. To specify stainless Grade 18-8 bolts, add an SS at the end of the kit number (MK 501SS).

Please note that using stainless steel bolts may reduce the pressure rating of the assembly.

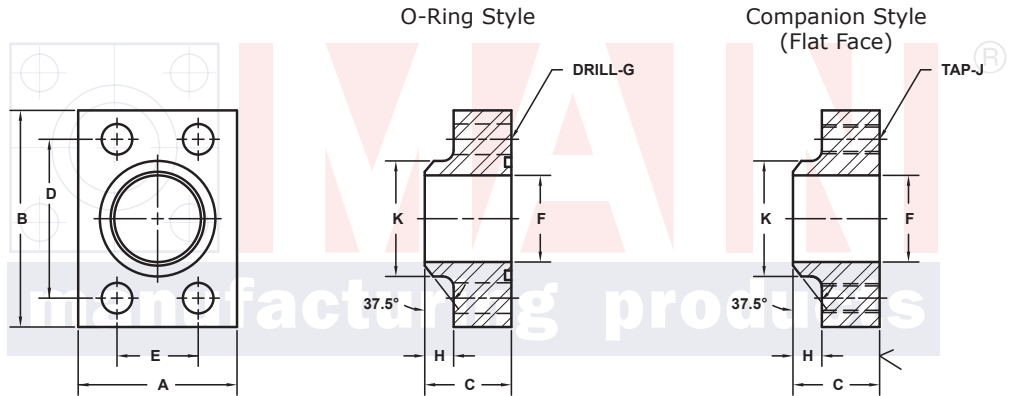

Model 6117 / 6119

Model 6118 / 6120

3181 TRI-PARK DR. GRAND BLANC, MI 48439 800-521-7918 810-953-1380 FAX 810-953-1385 INFO@MAINMFG.COM

## SAE J518 62 SERIES / ISO6162-2 PATTERN

FLANGE SIZE	PIPE SIZE	PART NUMBER	A	B	C	D	E	F	Gmm		H	K	MOUNTING KIT®			WT
									Jmm				PART NO.	SCREW SIZE	O-RING	
1/2	1/2	6119-08-08DM8	1.75	2.22	1.25	1.594	.718	.47	8.5	.38	.88	MKM 512	M8 x 35	210	.8	
		M8x1.25														
3/4	1/2	6119-12-08DM10	2.00	2.81	1.25	2.000	.937	.47	10.5	.38	.88	MKM 1525	M10 x 35	214	1.3	
		M10x1.5														
3/4	3/4	6119-12-12DM10	2.00	2.81	1.25	2.000	.937	.61	10.5	.38	1.12	MKM 1525	M10 x 35	214	1.3	
		M10x1.5														
1	3/4	6119-16-12DM12	2.25	3.19	1.25	2.250	1.093	.61	12.5	.38	1.12	MKM 4569	M12 x 40	219	1.7	
		M12x1.75														
1	1	6119-16-16DM12	2.25	3.19	1.25	2.250	1.093	.81	12.5	.38	1.38	MKM 4569	M12 x 40	219	1.5	
		M12x1.75														
1 1/4	1	6119-20-16DM12‡	2.75	3.75	1.25	2.625	1.250	.81	13.0	.38	1.38	MKM 1527	M12 x 40	222	2.4	
		M12x1.75														
1 1/4	1 1/4	6119-20-20DM12‡	2.75	3.75	1.25	2.625	1.250	1.16	13.0	.38	1.75	MKM 1527	M12 x 40	222	2.1	
		M12x1.75														
1 1/4	1 1/2	6120-20-24DM12‡	3.00	3.75	1.50	2.625	1.250	1.25	---	.50	2.00	---	---	---	3.1	
		M12x1.75														

① Order Separately

© Other Pipe and Tube Sizes are Available

40 NOTE: DIMENSIONS ARE IN INCHES UNLESS OTHERWISE NOTED. † Also Available for M12 Bolts ‡ Also Available for M14 Bolts

© Copyright MAIN Mfg. 2017

# BUTT WELD IN-LINE FLANGES (Pg 2/2)

For Schedule 160 Pipe ⑥

## SAE J518 61 SERIES / ISO6162-1 PATTERN

FLANGE SIZE	PIPE SIZE	PART NUMBER	A	B	C	D	E	F	Gmm Jmm	H	K	MOUNTING KIT①			WT
												PART NO.	SCREW SIZE	O-RING	
2	1¼	6117-32-20DM12‡	3.25	4.00	1.50	3.062	1.688	1.16	13.0	.50	1.75	MKM 4552	M12 x 45	228	3.4
		6118-32-20DM12‡							M12x1.75			-----	---		
2	1½	6117-32-24DM12‡	3.25	4.00	1.50	3.062	1.688	1.34	13.0	.50	2.00	MKM 4552	M12 x 45	228	3.3
		6118-32-24DM12‡							M12x1.75			-----	---		
2	2	6117-32-32DM12‡	3.25	4.00	1.50	3.062	1.688	1.69	13.0	.50	2.50	MKM 4552	M12 x 45	228	2.8
		6118-32-32DM12‡							M12x1.75			-----	---		
2½ <sup>②</sup>	2	6117-40-32DM12‡	4.00	4.50	1.75	3.500	2.000	1.69	13.0	.50	2.50	MKM 2575	M12 x 50	232	5.7
		6118-40-32DM12‡							M12x1.75			-----	---		
2½ <sup>②</sup>	2½	6117-40-40DM12‡	4.00	4.50	1.75	3.500	2.000	2.12	13.0	.50	3.00	MKM 2575	M12 x 50	232	4.8
		6118-40-40DM12‡							M12x1.75			-----	---		
3 <sup>③</sup>	2½	6117-48-40DM16	4.50	5.31	2.00	4.188	2.438	2.12	17.0	.50	3.00	MKM 585	M16 x 60	237	8.7
		6118-48-40DM16							M16x2			-----	---		
3 <sup>③</sup>	3	6117-48-48DM16	4.50	5.31	2.00	4.188	2.438	2.62	17.0	.50	3.50	MKM 585	M16 x 60	237	7.2
		6118-48-48DM16							M16x2			-----	---		
3½ <sup>④</sup>	3	6117-56-48DM16	5.00	6.00	1.50	4.750	2.750	2.62	17.0	.50	3.50	MKM 1571	M16 x 50	241	7.2
		6118-56-48DM16							M16x2			-----	---		
3½ <sup>④</sup>	3½	6117-56-56DM16	5.00	6.00	1.50	4.750	2.750	3.00	17.0	.50	4.00	MKM 1571	M16 x 50	241	5.9
		6118-56-56DM16							M16x2			-----	---		
4 <sup>④</sup>	3	6117-64-48DM16	5.50	6.38	1.50	5.125	3.062	2.62	17.0	.50	3.50	MKM 1572	M16 x 50	245	8.6
		6118-64-48DM16							M16x2			-----	---		
4 <sup>④</sup>	4	6117-64-64DM16	5.50	6.38	1.50	5.125	3.062	3.44	17.0	.50	4.50	MKM 1572	M16 x 50	245	6.7
		6118-64-64DM16							M16x2			-----	---		

MOUNTING KITS listed contain carbon steel bolts and Buna N O-Ring. To specify stainless Grade 18-8 bolts, add an SS at the end of the kit number (MK 501SS).

Please note that using stainless steel bolts may reduce the pressure rating of the assembly.

MATERIAL:  
316L Stainless

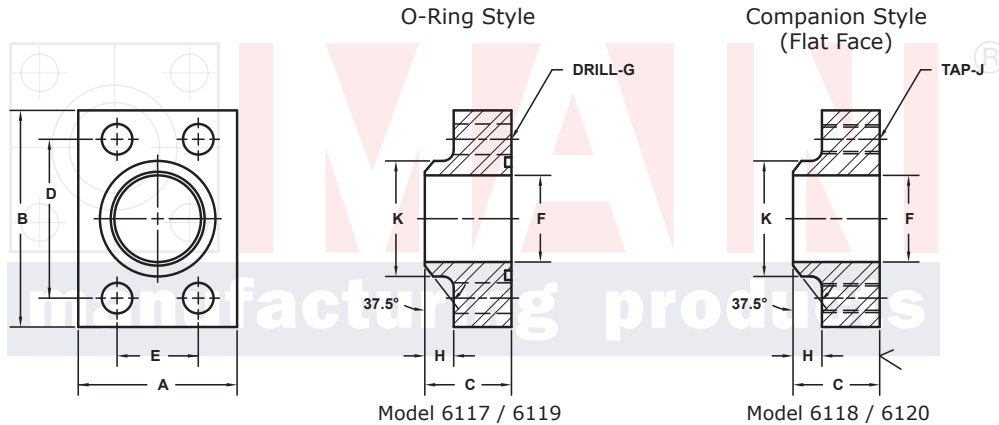

Model 6117 / 6119

Model 6118 / 6120

3181 TRI-PARK DR. GRAND BLANC, MI 48439 800-521-7918 810-953-1380 FAX 810-953-1385 INFO@MAINMFG.COM

## SAE J518 62 SERIES / ISO6162-2 PATTERN

FLANGE SIZE	PIPE SIZE	PART NUMBER	A	B	C	D	E	F	Gmm Jmm	H	K	MOUNTING KIT①			WT
												PART NO.	SCREW SIZE	O-RING	
1½	1¼	6119-24-20DM16	3.25	4.50	1.50	3.125	1.437	1.16	17.0	.50	1.75	MKM 562	M16 x 45	225	3.8
		6120-24-20DM16							M16x2			-----	---		
1½	1½	6119-24-24DM16	3.25	4.50	1.50	3.125	1.437	1.34	17.0	.50	2.00	MKM 562	M16 x 45	225	3.3
		6120-24-24DM16							M16x2			-----	---		
1½	2	-----	4.00	4.50	2.00	3.125	1.437	1.50	-----	.50	2.50	-----	-----	---	6.9
		6120-24-32DM16							M16x2			-----	---		
2	1½	6119-32-24DM20	4.00	5.25	1.75	3.812	1.750	1.34	21.0	.50	2.00	MKM 1548	M20 x 60	228	6.7
		6120-32-24DM20							M20x2.5			-----	---		
2	2	6119-32-32DM20	4.00	5.25	1.75	3.812	1.750	1.69	21.0	.50	2.50	MKM 1548	M20 x 60	228	5.9
		6120-32-32DM20							M20x2.5			-----	---		
2½	2	6119-40-32DM24	5.00	6.88	2.00	4.875	2.312	1.69	25.5	.50	2.50	MKM 1575	M24 x 70	232	13.2
		6120-40-32DM24							M24x3			-----	---		
2½	2½	6119-40-40DM24	5.00	6.88	2.00	4.875	2.312	2.12	25.5	.50	3.00	MKM 1575	M24 x 70	232	12.0
		6120-40-40DM24							M24x3			-----	---		
3	3	6119-48-48DM30	6.00	8.50	2.50	6.000	2.812	2.62	32.0	.50	3.50	MKM 1576	M30 x 100	237	23.3
		6120-48-48DM30							M30x3.5			-----	---		

① Order Separately ② 2500 PSI Max ③ 2000 PSI Max ④ 500 PSI Max

⑥ Other Pipe and Tube Sizes are Available

NOTE: DIMENSIONS ARE IN INCHES UNLESS OTHERWISE NOTED. + Also Available for M12 Bolts ‡ Also Available for M14 Bolts

© Copyright MAIN Mfg. 2017