

BUTT WELD ELBOW FLANGES (Pg 1/2)

For Schedule 80 Pipe ⑥

SAE BOLT PATTERN										61 SERIES					
FLANGE SIZE	PIPE SIZE	PART NUMBER	A	B	C	D	E	F	G J	H	K	MOUNTING KIT③			WT
												PART NO.	SCREW SIZE	O-RING	
1/2	1/2	6137-08-08D	2.00	2.12	1.44	1.500	.688	.53	.34	.75	.88	MK 541	5/16-18 x 2	210	1.3
		6138-08-08D							5/16-18						
3/4	1/2	6137-12-08D	2.25	2.62	1.70	1.875	.875	.53	.41	.88	.88	MK 542	3/8-16 x 2 1/2	214	2.1
		6138-12-08D							3/8-16						
3/4	3/4	6137-12-12D	2.25	2.62	1.70	1.875	.875	.73	.41	.88	1.12	MK 542	3/8-16 x 2 1/2	214	2.0
		6138-12-12D							3/8-16						
1	3/4	6137-16-12D	2.50	2.82	1.94	2.062	1.031	.73	.41	1.00	1.12	MK 543	3/8-16 x 2 3/4	219	2.8
		6138-16-12D							3/8-16						
1	1	6137-16-16D	2.50	2.82	1.94	2.062	1.031	.94	.41	1.00	1.38	MK 543	3/8-16 x 2 3/4	219	2.8
		6138-16-16D							3/8-16						
1 1/4	1	6137-20-16D	3.00	3.19	2.40	2.312	1.188	.94	.47	1.25	1.38	MK 578	7/16-14 x 3 1/4	222	4.8
		6138-20-16D							7/16-14						
1 1/4	1 1/4	6137-20-20D	3.00	3.19	2.40	2.312	1.188	1.23	.47	1.25	1.75	MK 578	7/16-14 x 3 1/4	222	4.6
		6138-20-20D							7/16-14						
1 1/4	1 1/2	6137-20-24D	3.00	3.19	3.00	2.312	1.188	1.48	.47	1.25	2.00	MK 591	7/16-14 x 4	222	5.5
		6138-20-24D							7/16-14						
1 1/2	1 1/4	6137-24-20D	3.25	3.75	2.90	2.750	1.406	1.23	.53	1.38	1.75	MK 545	1/2-13 x 4	225	7.0
		6138-24-20D							1/2-13						
1 1/2	1 1/2	6137-24-24D	3.25	3.75	2.90	2.750	1.406	1.48	.53	1.38	2.00	MK 545	1/2-13 x 4	225	6.8
		6138-24-24D							1/2-13						
1 1/2	2	6137-24-32D	3.50	3.75	3.50	2.750	1.406	1.94	.53	1.38	2.50	MK 579	1/2-13 x 4 1/2	225	9.1
		6138-24-32D							1/2-13						

MATERIAL:
316L Stainless

MOUNTING KITS listed contain carbon steel bolts and Buna N O-Ring. To specify stainless Grade 18-8 bolts, add an SS at the end of the kit number (MK 501SS).

Please note that using stainless steel bolts may reduce the pressure rating of the assembly.

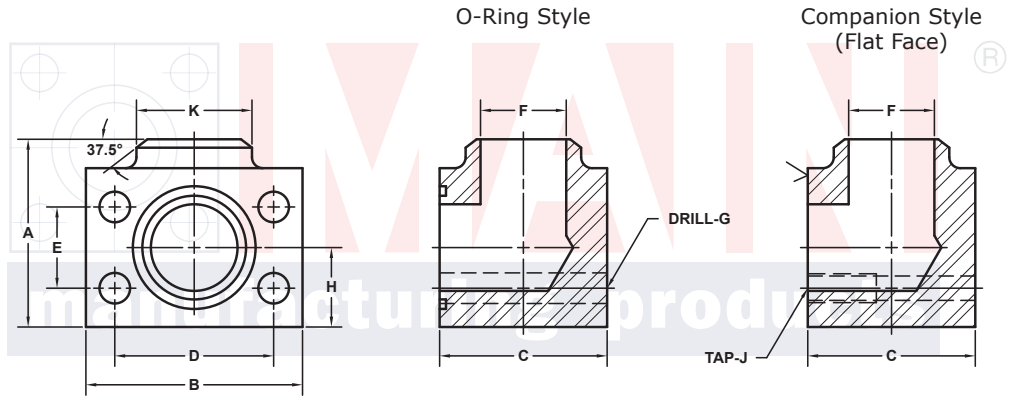
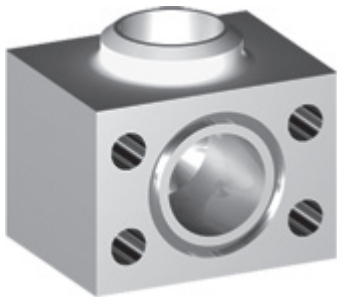

Model 6137 / 6139

Model 6138 / 6140

3181 TRI-PARK DR. GRAND BLANC, MI 48439 800-521-7918 810-953-1380 FAX 810-953-1385 INFO@MAINMFG.COM

SAE BOLT PATTERN										62 SERIES					
FLANGE SIZE	PIPE SIZE	PART NUMBER	A	B	C	D	E	F	G J	H	K	MOUNTING KIT③			WT
												PART NO.	SCREW SIZE	O-RING	
1/2	1/2	6139-08-08D	2.25	2.22	1.46	1.594	.718	.53	.34	.88	.88	MK 541	5/16-18 x 2	210	1.6
		6140-08-08D							5/16-18						
3/4	1/2	6139-12-08D	2.50	2.81	1.70	2.000	.937	.53	.41	1.00	.88	MK 542	3/8-16 x 2 1/2	214	2.6
		6140-12-08D							3/8-16						
3/4	3/4	6139-12-12D	2.50	2.81	1.70	2.000	.937	.73	.41	1.00	1.12	MK 542	3/8-16 x 2 1/2	214	2.5
		6140-12-12D							3/8-16						
1	3/4	6139-16-12D	2.75	3.19	2.21	2.250	1.093	.73	.47	1.12	1.12	MK 2533	7/16-14 x 3	219	4.1
		6140-16-12D							7/16-14						
1	1	6139-16-16D	2.75	3.19	2.21	2.250	1.093	.94	.47	1.12	1.38	MK 2533	7/16-14 x 3	219	4.1
		6140-16-16D							7/16-14						
1 1/4	1	6139-20-16D	3.25	3.75	2.44	2.625	1.250	.94	.53	1.38	1.38	MK 552	1/2-13 x 3 1/4	222	6.4
		6140-20-16D							1/2-13						
1 1/4	1 1/4	6139-20-20D	3.25	3.75	2.44	2.625	1.250	1.23	.53	1.38	1.75	MK 552	1/2-13 x 3 1/4	222	6.2
		6140-20-20D							1/2-13						

① Order Separately

⑥ Schedules 40, 160 and XXS also Stocked. Other Pipe and Tube Sizes are Available

BUTT WELD ELBOW FLANGES (Pg 2/2)

For Schedule 80 Pipe ©

SAE BOLT PATTERN										61 SERIES					
FLANGE SIZE	PIPE SIZE	PART NUMBER	A	B	C	D	E	F	G J	H	K	MOUNTING KIT ^①			WT
												PART NO.	SCREW SIZE	O-RING	
2	1 1/4	6137-32-20D	3.75	4.00	3.40	3.062	1.688	1.23	.53	1.62	1.75	MK 546	1/2-13 x 4 1/2	228	10.1
		6138-32-20D							1/2-13						
2	1 1/2	6137-32-24D	3.75	4.00	3.40	3.062	1.688	1.48	.53	1.62	2.00	MK 546	1/2-13 x 4 1/2	228	9.9
		6138-32-24D							1/2-13						
2	2	6137-32-32D	3.75	4.00	3.40	3.062	1.688	1.94	.53	1.62	2.50	MK 546	1/2-13 x 4 1/2	228	9.4
		6138-32-32D							1/2-13						
2 1/2 ^②	2	6137-40-32D	4.50	4.50	3.96	3.500	2.000	1.94	.53	2.00	2.50	MK 547	1/2-13 x 5	232	15.4
		6138-40-32D							1/2-13						
2 1/2 ^②	2 1/2	6137-40-40D	4.50	4.50	3.96	3.500	2.000	2.32	.53	2.00	3.00	MK 547	1/2-13 x 5	232	14.8
		6138-40-40D							1/2-13						
3 ^③	2 1/2	6137-48-40D	5.00	5.31	4.96	4.188	2.438	2.32	.66	2.25	3.00	MK 548	5/8-11 x 6	237	24.9
		6138-48-40D							5/8-11						
3 ^③	3	6137-48-48D	5.00	5.31	4.96	4.188	2.438	2.90	.66	2.25	3.50	MK 548	5/8-11 x 6	237	23.6
		6138-48-48D							5/8-11						
3 1/2 ^④	3	6137-56-48D	5.50	6.00	5.40	4.750	2.750	2.90	.66	2.50	3.50	MK 549	5/8-11 x 6 1/2	241	32.8
		6138-56-48D							5/8-11						
3 1/2 ^④	3 1/2	6137-56-56D	5.50	6.00	5.40	4.750	2.750	3.36	.66	2.50	4.00	MK 549	5/8-11 x 6 1/2	241	31.5
		6138-56-56D							5/8-11						
4 ^④	3	6137-64-48D	6.00	6.38	5.96	5.125	3.062	2.90	.66	2.75	3.50	MK 550	5/8-11 x 7	245	42.0
		6138-64-48D							5/8-11						
4 ^④	4	6137-64-64D	6.00	6.38	5.96	5.125	3.062	3.83	.66	2.75	4.50	MK 550	5/8-11 x 7	245	38.8
		6138-64-64D							5/8-11						

MOUNTING KITS listed contain carbon steel bolts and Buna N O-Ring. To specify stainless Grade 18-8 bolts, add an SS at the end of the kit number (MK 501SS).

Please note that using stainless steel bolts may reduce the pressure rating of the assembly.

MATERIAL:
316L Stainless

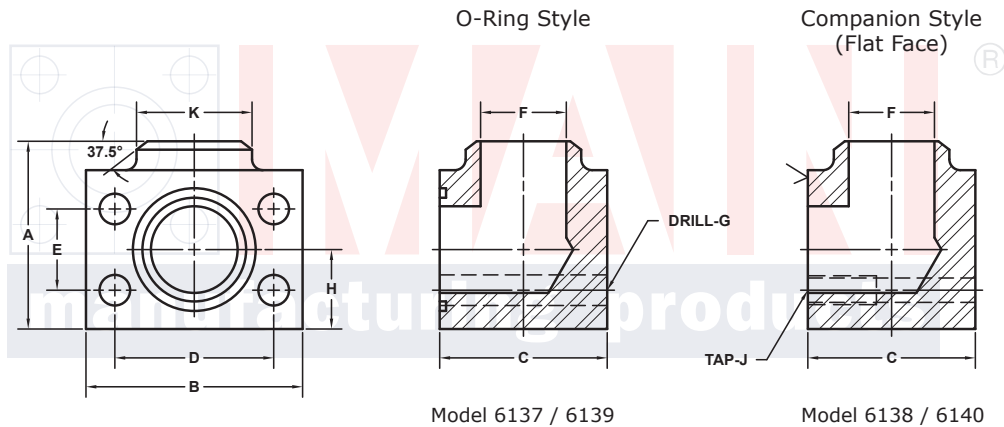

Model 6137 / 6139

Model 6138 / 6140

3181 TRI-PARK DR. GRAND BLANC, MI 48439 800-521-7918 810-953-1380 FAX 810-953-1385 INFO@MAINMFG.COM

SAE BOLT PATTERN										62 SERIES					
FLANGE SIZE	PIPE SIZE	PART NUMBER	A	B	C	D	E	F	G J	H	K	MOUNTING KIT ^①			WT
												PART NO.	SCREW SIZE	O-RING	
1 1/2	1 1/4	6139-24-20D	3.75	4.50	2.96	3.125	1.437	1.23	.66	1.62	1.75	MK 553	5/8-11 x 4	225	10.4
		6140-24-20D							5/8-11						
1 1/2	1 1/2	6139-24-24D	3.75	4.50	2.96	3.125	1.437	1.48	.66	1.62	2.00	MK 553	5/8-11 x 4	225	10.2
		6140-24-24D							5/8-11						
2	1 1/2	6139-32-24D	4.50	5.25	3.46	3.812	1.750	1.48	.78	2.00	2.00	MK 554	3/4-10 x 4 1/2	228	17.0
		6140-32-24D							3/4-10						
2	2	6139-32-32D	4.50	5.25	3.46	3.812	1.750	1.94	.78	2.00	2.50	MK 554	3/4-10 x 4 1/2	228	16.4
		6140-32-32D							3/4-10						
2 1/2	2	6139-40-32D	5.50	6.88	4.50	4.875	2.312	1.94	.94	2.50	2.50	MK 2557	7/8-9 x 6	232	36.6
		6140-40-32D							7/8-9						
2 1/2	2 1/2	6139-40-40D	5.50	6.88	4.50	4.875	2.312	2.32	.94	2.50	3.00	MK 2557	7/8-9 x 6	232	35.8
		6140-40-40D							7/8-9						
3	3	6139-48-48D	6.50	8.50	5.00	6.000	2.812	2.90	1.19	3.00	3.50	MK 756	1 1/8-7 x 7	237	58.0
		6140-48-48D							1 1/8-7						

① Order Separately

② 2500 PSI Max ③ 2000 PSI Max ④ 500 PSI Max

⑥ Schedules 40, 160 and XXS also Stocked. Other Pipe and Tube Sizes are Available