

# BUTT WELD ELBOW FLANGES (Pg 1/2)

For Schedule 80 Pipe ⑥

SAE BOLT PATTERN			61 SERIES												
FLANGE SIZE	PIPE SIZE	PART NUMBER	A	B	C	D	E	F	G	H	K	MOUNTING KIT®			WT
									J			PART NO.	SCREW SIZE	O-RING	
1/2	1/2	1137-08-08	2.00	2.12	1.44	1.500	.688	.53	.34	.75	.88	MK 541	5/16-18 x 2	210	1.3
		1138-08-08							5/16-18						
3/4	1/2	1137-12-08	2.25	2.62	1.70	1.875	.875	.53	.41	.88	.88	MK 542	3/8-16 x 2 1/2	214	2.1
		1138-12-08							3/8-16						
3/4	3/4	1137-12-12	2.25	2.62	1.70	1.875	.875	.73	.41	.88	1.12	MK 542	3/8-16 x 2 1/2	214	2.0
		1138-12-12							3/8-16						
1	3/4	1137-16-12	2.50	2.82	1.94	2.062	1.031	.73	.41	1.00	1.12	MK 543	3/8-16 x 2 3/4	219	2.8
		1138-16-12							3/8-16						
1	1	1137-16-16	2.50	2.82	1.94	2.062	1.031	.94	.41	1.00	1.38	MK 543	3/8-16 x 2 3/4	219	2.8
		1138-16-16							3/8-16						
1 1/4	1	1137-20-16	3.00	3.19	2.40	2.312	1.188	.94	.47	1.25	1.38	MK 578	7/16-14 x 3 1/4	222	4.8
		1138-20-16							7/16-14						
1 1/4	1 1/4	1137-20-20	3.00	3.19	2.40	2.312	1.188	1.23	.47	1.25	1.75	MK 578	7/16-14 x 3 1/4	222	4.6
		1138-20-20							7/16-14						
1 1/4	1 1/2	1137-20-24	3.00	3.19	3.00	2.312	1.188	1.48	.47	1.25	2.00	MK 591	7/16-14 x 4	222	5.5
		1138-20-24							7/16-14						
1 1/2	1 1/4	1137-24-20	3.25	3.75	2.90	2.750	1.406	1.23	.53	1.38	1.75	MK 545	1/2-13 x 4	225	7.0
		1138-24-20							1/2-13						
1 1/2	1 1/2	1137-24-24	3.25	3.75	2.90	2.750	1.406	1.48	.53	1.38	2.00	MK 545	1/2-13 x 4	225	6.8
		1138-24-24							1/2-13						
1 1/2	2	1137-24-32	3.50	3.75	3.50	2.750	1.406	1.94	.53	1.38	2.50	MK 579	1/2-13 x 4 1/2	225	9.1
		1138-24-32							1/2-13						

MATERIAL:  
Low Carbon Steel

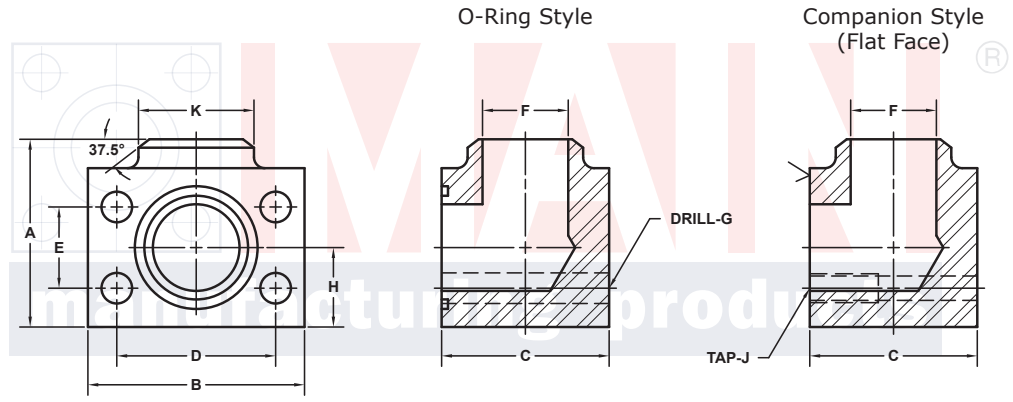
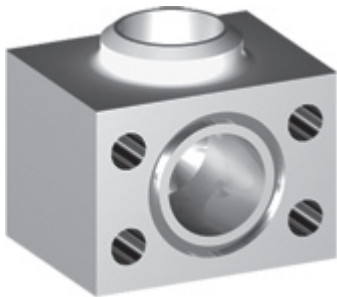

Model 1137 / 1139

Model 1138 / 1140

3181 TRI-PARK DR. GRAND BLANC, MI 48439 800-521-7918 810-953-1380 FAX 810-953-1385 INFO@MAINMFG.COM

SAE BOLT PATTERN			62 SERIES												
FLANGE SIZE	PIPE SIZE	PART NUMBER	A	B	C	D	E	F	G	H	K	MOUNTING KIT®			WT
									J			PART NO.	SCREW SIZE	O-RING	
1/2	1/2	1139-08-08	2.25	2.22	1.46	1.594	.718	.53	.34	.88	.88	MK 541	5/16-18 x 2	210	1.6
		1140-08-08							5/16-18						
3/4	1/2	1139-12-08	2.50	2.81	1.70	2.000	.937	.53	.41	1.00	.88	MK 542	3/8-16 x 2 1/2	214	2.6
		1140-12-08							3/8-16						
3/4	3/4	1139-12-12	2.50	2.81	1.70	2.000	.937	.73	.41	1.00	1.12	MK 542	3/8-16 x 2 1/2	214	2.5
		1140-12-12							3/8-16						
1	3/4	1139-16-12	2.75	3.19	2.21	2.250	1.093	.73	.47	1.12	1.12	MK 2533	7/16-14 x 3	219	4.1
		1140-16-12							7/16-14						
1	1	1139-16-16	2.75	3.19	2.21	2.250	1.093	.94	.47	1.12	1.38	MK 2533	7/16-14 x 3	219	4.1
		1140-16-16							7/16-14						
1 1/4	1	1139-20-16	3.25	3.75	2.44	2.625	1.250	.94	.53	1.38	1.38	MK 552	1/2-13 x 3 1/4	222	6.4
		1140-20-16							1/2-13						
1 1/4	1 1/4	1139-20-20	3.25	3.75	2.44	2.625	1.250	1.23	.53	1.38	1.75	MK 552	1/2-13 x 3 1/4	222	6.2
		1140-20-20							1/2-13						

① Order Separately

⑥ Schedules 40 and XXS also Stocked. Other Pipe and Tube Sizes are Available

# BUTT WELD ELBOW FLANGES (Pg 2/2)

For Schedule 80 Pipe ©

SAE BOLT PATTERN										61 SERIES					
FLANGE SIZE	PIPE SIZE	PART NUMBER	A	B	C	D	E	F	G J	H	K	MOUNTING KIT®			WT
												PART NO.	SCREW SIZE	O-RING	
2	1¼	1137-32-20	3.75	4.00	3.40	3.062	1.688	1.23	.53	1.62	1.75	MK 546	1/2-13 x 4 1/2	228	10.1
		1138-32-20							1/2-13						
2	1½	1137-32-24	3.75	4.00	3.40	3.062	1.688	1.48	.53	1.62	2.00	MK 546	1/2-13 x 4 1/2	228	9.9
		1138-32-24							1/2-13						
2	2	1137-32-32	3.75	4.00	3.40	3.062	1.688	1.94	.53	1.62	2.50	MK 546	1/2-13 x 4 1/2	228	9.4
		1138-32-32							1/2-13						
2½ <sup>②</sup>	2	1137-40-32	4.50	4.50	3.96	3.500	2.000	1.94	.53	2.00	2.50	MK 547	1/2-13 x 5	232	15.4
		1138-40-32							1/2-13						
2½ <sup>②</sup>	2½	1137-40-40	4.50	4.50	3.96	3.500	2.000	2.32	.53	2.00	3.00	MK 547	1/2-13 x 5	232	14.8
		1138-40-40							1/2-13						
3 <sup>③</sup>	2½	1137-48-40	5.00	5.31	4.96	4.188	2.438	2.32	.66	2.25	3.00	MK 548	5/8-11 x 6	237	24.9
		1138-48-40							5/8-11						
3 <sup>③</sup>	3	1137-48-48	5.00	5.31	4.96	4.188	2.438	2.90	.66	2.25	3.50	MK 548	5/8-11 x 6	237	23.6
		1138-48-48							5/8-11						
3½ <sup>④</sup>	3	1137-56-48	5.50	6.00	5.40	4.750	2.750	2.90	.66	2.50	3.50	MK 549	5/8-11 x 6 1/2	241	32.8
		1138-56-48							5/8-11						
3½ <sup>④</sup>	3½	1137-56-56	5.50	6.00	5.40	4.750	2.750	3.36	.66	2.50	4.00	MK 549	5/8-11 x 6 1/2	241	31.5
		1138-56-56							5/8-11						
4 <sup>④</sup>	3	1137-64-48	6.00	6.38	5.96	5.125	3.062	2.90	.66	2.75	3.50	MK 550	5/8-11 x 7	245	42.0
		1138-64-48							5/8-11						
4 <sup>④</sup>	4	1137-64-64	6.00	6.38	5.96	5.125	3.062	3.83	.66	2.75	4.50	MK 550	5/8-11 x 7	245	38.8
		1138-64-64							5/8-11						

MATERIAL:  
Low Carbon Steel

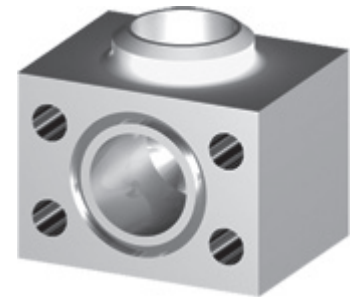
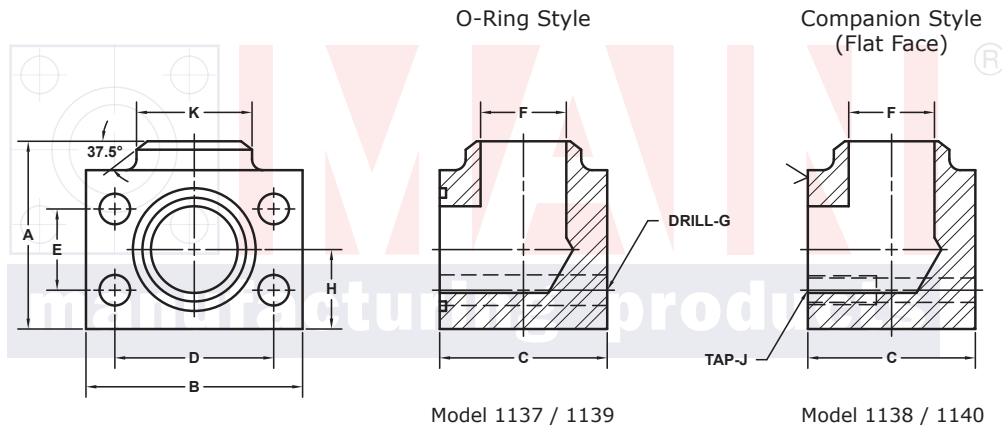

3181 TRI-PARK DR. GRAND BLANC, MI 48439 800-521-7918 810-953-1380 FAX 810-953-1385 INFO@MAINMFG.COM

SAE BOLT PATTERN										62 SERIES					
FLANGE SIZE	PIPE SIZE	PART NUMBER	A	B	C	D	E	F	G J	H	K	MOUNTING KIT®			WT
												PART NO.	SCREW SIZE	O-RING	
1½	1¼	1139-24-20	3.75	4.50	2.96	3.125	1.437	1.23	.66	1.62	1.75	MK 553	5/8-11 x 4	225	10.4
		1140-24-20							5/8-11						
1½	1½	1139-24-24	3.75	4.50	2.96	3.125	1.437	1.48	.66	1.62	2.00	MK 553	5/8-11 x 4	225	10.2
		1140-24-24							5/8-11						
2	1½	1139-32-24	4.50	5.25	3.46	3.812	1.750	1.48	.78	2.00	2.00	MK 554	3/4-10 x 4 1/2	228	17.0
		1140-32-24							3/4-10						
2	2	1139-32-32	4.50	5.25	3.46	3.812	1.750	1.94	.78	2.00	2.50	MK 554	3/4-10 x 4 1/2	228	16.4
		1140-32-32							3/4-10						
2½	2	1139-40-32	5.50	6.88	4.50	4.875	2.312	1.94	.94	2.50	2.50	MK 2557	7/8-9 x 6	232	36.6
		1140-40-32							7/8-9						
2½	2½	1139-40-40	5.50	6.88	4.50	4.875	2.312	2.32	.94	2.50	3.00	MK 2557	7/8-9 x 6	232	35.8
		1140-40-40							7/8-9						
3	3	1139-48-48	6.50	8.50	5.00	6.000	2.812	2.90	1.19	3.00	3.50	MK 756	1 1/8-7 x 7	237	58.0
		1140-48-48							1 1/8-7						

① Order Separately    ② 2500 PSI Max    ③ 2000 PSI Max    ④ 500 PSI Max  
 ® Schedules 40 and XXS also Stocked. Other Pipe and Tube Sizes are Available