

BUTT WELD ELBOW FLANGES (Pg 1/2)

For Schedule XXS Pipe ⑥

FLANGE SIZE	PIPE SIZE	SAE BOLT PATTERN							61 SERIES					WT	
		PART NUMBER	A	B	C	D	E	F	G J	H	K	MOUNTING KIT®			
												PART NO.	SCREW SIZE		O-RING
1/2	1/2	6145-08-08D	2.00	2.12	1.44	1.500	.688	.25	.34	.75	.88	MK 541	5/16-18 x 2	210	1.3
		6146-08-08D							5/16-18						
3/4	1/2	6145-12-08D	2.25	2.62	1.70	1.875	.875	.25	.41	.88	.88	MK 542	3/8-16 x 2 1/2	214	2.1
		6146-12-08D							3/8-16						
3/4	3/4	6145-12-12D	2.25	2.62	1.70	1.875	.875	.44	.41	.88	1.12	MK 542	3/8-16 x 2 1/2	214	2.1
		6146-12-12D							3/8-16						
1	3/4	6145-16-12D	2.50	2.82	1.94	2.062	1.031	.44	.41	1.00	1.12	MK 543	3/8-16 x 2 3/4	219	2.9
		6146-16-12D							3/8-16						
1	1	6145-16-16D	2.50	2.82	1.94	2.062	1.031	.60	.41	1.00	1.38	MK 543	3/8-16 x 2 3/4	219	2.8
		6146-16-16D							3/8-16						
1 1/4	1	6145-20-16D	3.00	3.19	2.40	2.312	1.188	.60	.47	1.25	1.38	MK 578	7/16-14 x 3 1/4	222	4.8
		6146-20-16D							7/16-14						
1 1/4	1 1/4	6145-20-20D	3.00	3.19	2.40	2.312	1.188	.89	.47	1.25	1.75	MK 578	7/16-14 x 3 1/4	222	4.7
		6146-20-20D							7/16-14						
1 1/4	1 1/2	6145-20-24D	3.00	3.19	3.00	2.312	1.188	1.10	.47	1.25	2.00	MK 591	7/16-14 x 4	222	5.8
		6146-20-24D							7/16-14						
1 1/2	1 1/4	6145-24-20D	3.25	3.75	2.90	2.750	1.406	.89	.53	1.38	1.75	MK 545	1/2-13 x 4	225	7.2
		6146-24-20D							1/2-13						
1 1/2	1 1/2	6145-24-24D	3.25	3.75	2.90	2.750	1.406	1.10	.53	1.38	2.00	MK 545	1/2-13 x 4	225	7.1
		6146-24-24D							1/2-13						
1 1/2	2	6145-24-32D	3.50	3.75	3.50	2.750	1.406	1.50	.53	1.38	2.50	MK 579	1/2-13 x 4 1/2	225	9.2
		6146-24-32D							1/2-13						

MATERIAL:
316L Stainless

MOUNTING KITS listed contain carbon steel bolts and Buna N O-Ring. To specify stainless Grade 18-8 bolts, add an SS at the end of the kit number (MK 501SS).

Please note that using stainless steel bolts may reduce the pressure rating of the assembly.

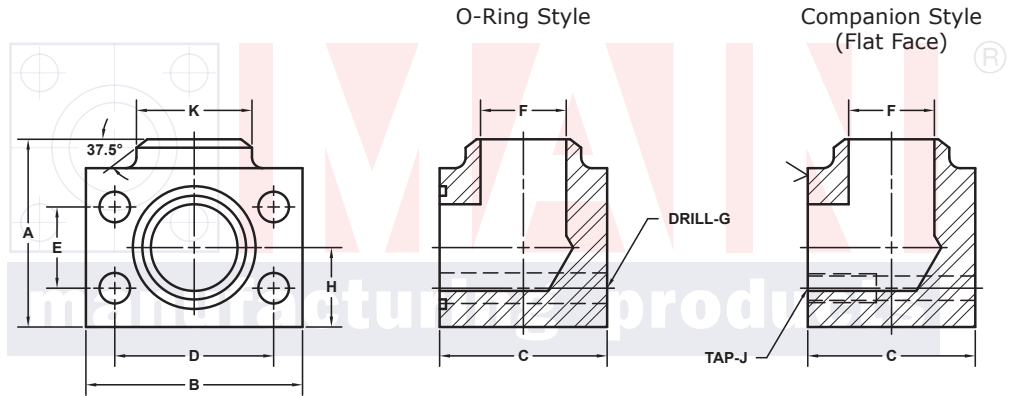
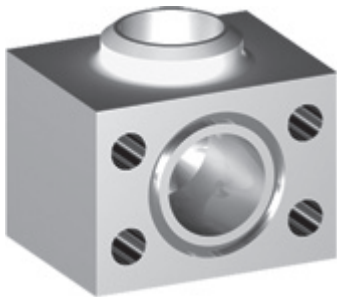

Model 6145 / 6147

Model 6146 / 6148

3181 TRI-PARK DR. GRAND BLANC, MI 48439 800-521-7918 810-953-1380 FAX 810-953-1385 INFO@MAINMFG.COM

FLANGE SIZE	PIPE SIZE	SAE BOLT PATTERN							62 SERIES					WT	
		PART NUMBER	A	B	C	D	E	F	G J	H	K	MOUNTING KIT®			
												PART NO.	SCREW SIZE		O-RING
1/2	1/2	6147-08-08D	2.25	2.22	1.46	1.594	.718	.25	.34	.88	.88	MK 541	5/16-18 x 2	210	1.6
		6148-08-08D							5/16-18						
3/4	1/2	6147-12-08D	2.50	2.81	1.70	2.000	.937	.25	.41	1.00	.88	MK 542	3/8-16 x 2 1/2	214	2.6
		6148-12-08D							3/8-16						
3/4	3/4	6147-12-12D	2.50	2.81	1.70	2.000	.937	.44	.41	1.00	1.12	MK 542	3/8-16 x 2 1/2	214	2.6
		6148-12-12D							3/8-16						
1	3/4	6147-16-12D	2.75	3.19	2.21	2.250	1.093	.44	.47	1.12	1.12	MK 2533	7/16-14 x 3	219	4.0
		6148-16-12D							7/16-14						
1	1	6147-16-16D	2.75	3.19	2.21	2.250	1.093	.60	.47	1.12	1.38	MK 2533	7/16-14 x 3	219	4.0
		6148-16-16D							7/16-14						
1 1/4	1	6147-20-16D	3.25	3.75	2.44	2.625	1.250	.60	.53	1.38	1.38	MK 552	1/2-13 x 3 1/4	222	6.3
		6148-20-16D							1/2-13						
1 1/4	1 1/4	6147-20-20D	3.25	3.75	2.44	2.625	1.250	.89	.53	1.38	1.75	MK 552	1/2-13 x 3 1/4	222	6.3
		6148-20-20D							1/2-13						

① Order Separately

⑥ Schedules 40, 80 and 160 also Stocked. Other Pipe and Tube Sizes are Available

BUTT WELD ELBOW FLANGES (Pg 2/2)

For Schedule XXS Pipe ⑥

SAE BOLT PATTERN										61 SERIES					
FLANGE SIZE	PIPE SIZE	PART NUMBER	A	B	C	D	E	F	G J	H	K	MOUNTING KIT①			WT
												PART NO.	SCREW SIZE	O-RING	
2	1¼	6145-32-20D	3.75	4.00	3.40	3.062	1.688	.89	.53 1/2-13	1.62	1.75	MK 546	1/2-13 x 4 1/2	228	10.4
		6146-32-20D										-----	---		
2	1½	6145-32-24D	3.75	4.00	3.40	3.062	1.688	1.10	.53 1/2-13	1.62	2.00	MK 546	1/2-13 x 4 1/2	228	10.2
		6146-32-24D										-----	---		
2	2	6145-32-32D	4.00	4.00	3.40	3.062	1.688	1.50	.53 1/2-13	1.62	2.50	MK 546	1/2-13 x 4 1/2	228	10.2
		6146-32-32D										-----	---		
2½ ^②	2	6145-40-32D	4.75	4.50	3.96	3.500	2.000	1.50	.53 1/2-13	2.00	2.50	MK 547	1/2-13 x 5	232	16.3
		6146-40-32D										-----	---		
2½ ^②	2½	6145-40-40D	4.75	4.50	3.96	3.500	2.000	1.77	.53 1/2-13	2.00	3.00	MK 547	1/2-13 x 5	232	16.1
		6146-40-40D										-----	---		
3 ^③	2½	6145-48-40D	5.25	5.31	4.96	4.188	2.438	1.77	.66 5/8-11	2.25	3.00	MK 548	5/8-11 x 6	237	26.3
		6146-48-40D										-----	---		
3 ^③	3	6145-48-48D	5.25	5.31	4.96	4.188	2.438	2.30	.66 5/8-11	2.25	3.50	MK 548	5/8-11 x 6	237	25.5
		6146-48-48D										-----	---		
3½ ^④	3	6145-56-48D	5.75	6.00	5.40	4.750	2.750	2.30	.66 5/8-11	2.50	3.50	MK 549	5/8-11 x 6 1/2	241	34.8
		6146-56-48D										-----	---		
3½ ^④	3½	6145-56-56D	5.75	6.00	5.40	4.750	2.750	2.73	.66 5/8-11	2.50	4.00	MK 549	5/8-11 x 6 1/2	241	33.9
		6146-56-56D										-----	---		
4 ^④	3	6145-64-48D	6.25	6.38	5.96	5.125	3.062	2.30	.66 5/8-11	2.75	3.50	MK 550	5/8-11 x 7	245	44.2
		6146-64-48D										-----	---		
4 ^④	4	6145-64-64D	6.25	6.38	5.96	5.125	3.062	3.15	.66 5/8-11	2.75	4.50	MK 550	5/8-11 x 7	245	42.0
		6146-64-64D										-----	---		

MOUNTING KITS listed contain carbon steel bolts and Buna N O-Ring. To specify stainless Grade 18-8 bolts, add an SS at the end of the kit number (MK 501SS).

Please note that using stainless steel bolts may reduce the pressure rating of the assembly.

MATERIAL:
316L Stainless

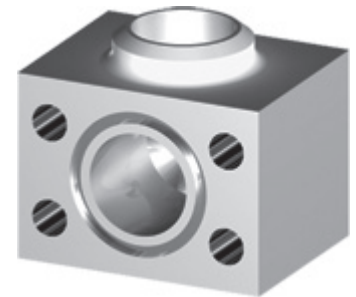
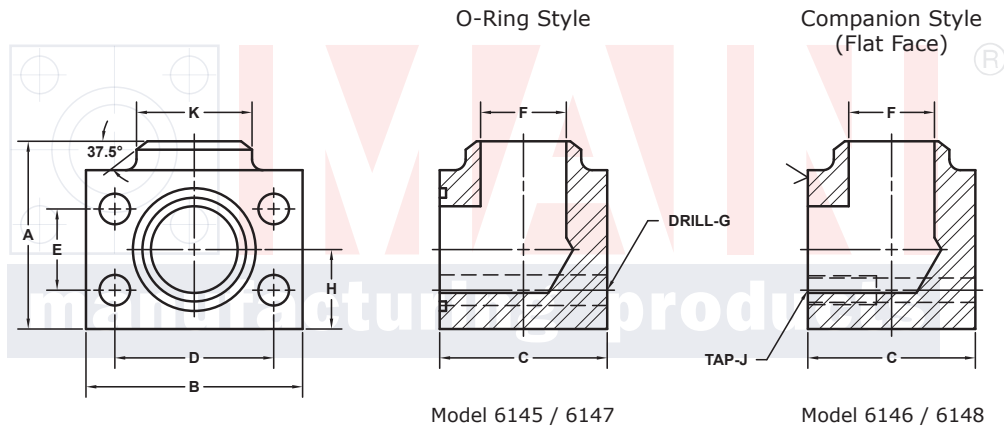

3181 TRI-PARK DR. GRAND BLANC, MI 48439 800-521-7918 810-953-1380 FAX 810-953-1385 INFO@MAINMFG.COM

SAE BOLT PATTERN										62 SERIES					
FLANGE SIZE	PIPE SIZE	PART NUMBER	A	B	C	D	E	F	G J	H	K	MOUNTING KIT①			WT
												PART NO.	SCREW SIZE	O-RING	
1½	1¼	6147-24-20D	4.00	4.50	2.96	3.125	1.437	.89	.66 5/8-11	1.62	1.75	MK 553	5/8-11 x 4	225	10.8
		6148-24-20D										-----	---		
1½	1½	6147-24-24D	3.75	4.50	2.96	3.125	1.437	1.10	.66 5/8-11	1.62	2.00	MK 553	5/8-11 x 4	225	10.5
		6148-24-24D										-----	---		
2	1½	6147-32-24D	4.50	5.25	3.46	3.812	1.750	1.10	.78 3/4-10	2.00	2.00	MK 554	3/4-10 x 4 1/2	228	17.4
		6148-32-24D										-----	---		
2	2	6147-32-32D	4.75	5.25	3.46	3.812	1.750	1.50	.78 3/4-10	2.00	2.50	MK 554	3/4-10 x 4 1/2	228	17.3
		6148-32-32D										-----	---		
2½	2	6147-40-32D	5.88	6.88	4.50	4.875	2.312	1.50	.94 7/8-9	2.50	2.50	MK 2557	7/8-9 x 6	232	37.8
		6148-40-32D										-----	---		
2½	2½	6147-40-40D	5.88	6.88	4.50	4.875	2.312	1.77	.94 7/8-9	2.50	3.00	MK 2557	7/8-9 x 6	232	37.5
		6148-40-40D										-----	---		
3	3	6147-48-48D	7.00	8.50	5.00	6.000	2.812	2.30	1.19 1 1/8-7	3.00	3.50	MK 756	1 1/8-7 x 7	237	61.0
		6148-48-48D										-----	---		

① Order Separately ② 2500 PSI Max ③ 2000 PSI Max ④ 500 PSI Max
⑥ Schedules 40, 80 and 160 also Stocked. Other Pipe and Tube Sizes are Available