

# BUTT WELD ELBOW FLANGES (Pg 1/2)

For Schedule XXS Pipe ⑥

## SAE J518 61 SERIES / ISO6162-1 PATTERN

FLANGE SIZE	PIPE SIZE	PART NUMBER	A	B	C	D	E	F	Gmm	H	K	MOUNTING KIT®			WT
									Jmm			PART NO.	SCREW SIZE	O-RING	
1/2	1/2	6145-08-08DM8	2.00	2.12	1.44	1.500	.688	.25	8.5	.75	.88	MKM 541	M8 x 50	210	1.3
		M8x1.25							-----			---			
3/4	1/2	6145-12-08DM10	2.25	2.62	1.70	1.875	.875	.25	10.5	.88	.88	MKM 542	M10 x 60	214	2.1
		M10x1.5							-----			---			
3/4	3/4	6145-12-12DM10	2.25	2.62	1.70	1.875	.875	.44	10.5	.88	1.12	MKM 542	M10 x 60	214	2.1
		M10x1.5							-----			---			
1	3/4	6145-16-12DM10	2.50	2.82	1.94	2.062	1.031	.44	10.5	1.00	1.12	MKM 543	M10 x 65	219	2.9
		M10x1.5							-----			---			
1	1	6145-16-16DM10	2.50	2.82	1.94	2.062	1.031	.60	10.5	1.00	1.38	MKM 543	M10 x 65	219	2.8
		M10x1.5							-----			---			
1 1/4	1	6145-20-16DM10†	3.00	3.19	2.40	2.312	1.188	.60	10.5	1.25	1.38	MKM 4532	M10 x 75	222	4.8
		M10x1.5							-----			---			
1 1/4	1 1/4	6145-20-20DM10†	3.00	3.19	2.40	2.312	1.188	.89	10.5	1.25	1.75	MKM 4532	M10 x 75	222	4.7
		M10x1.5							-----			---			
1 1/4	1 1/2	6145-20-24DM10†	3.00	3.19	3.00	2.312	1.188	1.10	10.5	1.25	2.00	MKM 4597	M10 x 90	222	5.8
		M10x1.5							-----			---			
1 1/2	1 1/4	6145-24-20DM12‡	3.25	3.75	2.90	2.750	1.406	.89	13.0	1.38	1.75	MKM 4533	M12 x 90	225	7.2
		M12x1.75							-----			---			
1 1/2	1 1/2	6145-24-24DM12‡	3.25	3.75	2.90	2.750	1.406	1.10	13.0	1.38	2.00	MKM 4533	M12 x 90	225	7.1
		M12x1.75							-----			---			
1 1/2	2	6145-24-32DM12‡	3.50	3.75	3.50	2.750	1.406	1.50	13.0	1.38	2.50	MKM 3521	M12 x 100	225	9.2
		M12x1.75							-----			---			

MATERIAL:  
316L Stainless

MOUNTING KITS listed contain carbon steel bolts and Buna N O-Ring. To specify stainless Grade 18-8 bolts, add an SS at the end of the kit number (MK 501SS).

Please note that using stainless steel bolts may reduce the pressure rating of the assembly.

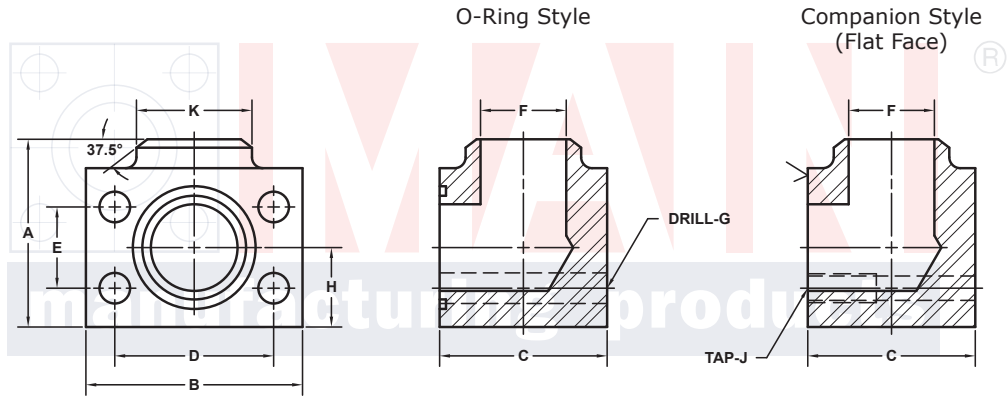
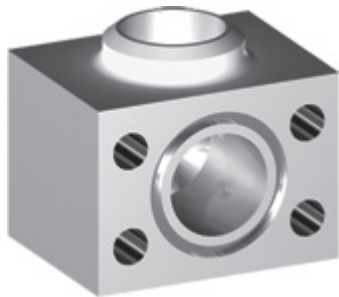

Model 6145 / 6147

Model 6146 / 6148

3181 TRI-PARK DR. GRAND BLANC, MI 48439 800-521-7918 810-953-1380 FAX 810-953-1385 INFO@MAINMFG.COM

## SAE J518 62 SERIES / ISO6162-2 PATTERN

FLANGE SIZE	PIPE SIZE	PART NUMBER	A	B	C	D	E	F	Gmm	H	K	MOUNTING KIT®			WT
									Jmm			PART NO.	SCREW SIZE	O-RING	
1/2	1/2	6147-08-08DM8	2.25	2.22	1.46	1.594	.718	.25	8.5	.88	.88	MKM 541	M8 x 50	210	1.6
		M8x1.25							-----			---			
3/4	1/2	6147-12-08DM10	2.50	2.81	1.70	2.000	.937	.25	10.5	1.00	.88	MKM 542	M10 x 60	214	2.6
		M10x1.5							-----			---			
3/4	3/4	6147-12-12DM10	2.50	2.81	1.70	2.000	.937	.44	10.5	1.00	1.12	MKM 542	M10 x 60	214	2.6
		M10x1.5							-----			---			
1	3/4	6147-16-12DM12	2.75	3.19	2.21	2.250	1.093	.44	12.5	1.12	1.12	MKM 2533	M12 x 75	219	4.0
		M12x1.75							-----			---			
1	1	6147-16-16DM12	2.75	3.19	2.21	2.250	1.093	.60	12.5	1.12	1.38	MKM 2533	M12 x 75	219	4.0
		M12x1.75							-----			---			
1 1/4	1	6147-20-16DM12‡	3.25	3.75	2.44	2.625	1.250	.60	13.0	1.38	1.38	MKM 578	M12 x 80	222	6.3
		M12x1.75							-----			---			
1 1/4	1 1/4	6147-20-20DM12‡	3.25	3.75	2.44	2.625	1.250	.89	13.0	1.38	1.75	MKM 578	M12 x 80	222	6.3
		M12x1.75							-----			---			

① Order Separately

⑥ Schedules 40, 80 and 160 also Stocked. Other Pipe and Tube Sizes are Available

50 NOTE: DIMENSIONS ARE IN INCHES UNLESS OTHERWISE NOTED. † Also Available for M12 Bolts ‡ Also Available for M14 Bolts

© Copyright MAIN Mfg. 2017

# BUTT WELD ELBOW FLANGES (Pg 2/2)

For Schedule XXS Pipe ⑥

## SAE J518 61 SERIES / ISO6162-1 PATTERN

FLANGE SIZE	PIPE SIZE	PART NUMBER	A	B	C	D	E	F	Gmm Jmm	H	K	MOUNTING KIT①			WT
												PART NO.	SCREW SIZE	O-RING	
2	1¼	6145-32-20DM12‡	3.75	4.00	3.40	3.062	1.688	.89	13.0	1.62	1.75	MKM 4534	M12 x 100	228	10.4
		6146-32-20DM12‡							M12x1.75			-----	---		
2	1½	6145-32-24DM12‡	3.75	4.00	3.40	3.062	1.688	1.10	13.0	1.62	2.00	MKM 4534	M12 x 100	228	10.2
		6146-32-24DM12‡							M12x1.75			-----	---		
2	2	6145-32-32DM12‡	4.00	4.00	3.40	3.062	1.688	1.50	13.0	1.62	2.50	MKM 4534	M12 x 100	228	10.2
		6146-32-32DM12‡							M12x1.75			-----	---		
2½ <sup>②</sup>	2	6145-40-32DM12‡	4.75	4.50	3.96	3.500	2.000	1.50	13.0	2.00	2.50	MKM 4535	M12 x 120	232	16.3
		6146-40-32DM12‡							M12x1.75			-----	---		
2½ <sup>②</sup>	2½	6145-40-40DM12‡	4.75	4.50	3.96	3.500	2.000	1.77	13.0	2.00	3.00	MKM 4535	M12 x 120	232	16.1
		6146-40-40DM12‡							M12x1.75			-----	---		
3 <sup>③</sup>	2½	6145-48-40DM16	5.25	5.31	4.96	4.188	2.438	1.77	17.0	2.25	3.00	MKM 548	M16 x 150	237	26.3
		6146-48-40DM16							M16x2			-----	---		
3 <sup>③</sup>	3	6145-48-48DM16	5.25	5.31	4.96	4.188	2.438	2.30	17.0	2.25	3.50	MKM 548	M16 x 150	237	25.5
		6146-48-48DM16							M16x2			-----	---		
3½ <sup>④</sup>	3	6145-56-48DM16	5.75	6.00	5.40	4.750	2.750	2.30	17.0	2.50	3.50	MKM 549	M16 x 160	241	34.8
		6146-56-48DM16							M16x2			-----	---		
3½ <sup>④</sup>	3½	6145-56-56DM16	5.75	6.00	5.40	4.750	2.750	2.73	17.0	2.50	4.00	MKM 549	M16 x 160	241	33.9
		6146-56-56DM16							M16x2			-----	---		
4 <sup>④</sup>	3	6145-64-48DM16	6.25	6.38	5.96	5.125	3.062	2.30	17.0	2.75	3.50	MKM 550	M16 x 180	245	44.2
		6146-64-48DM16							M16x2			-----	---		
4 <sup>④</sup>	4	6145-64-64DM16	6.25	6.38	5.96	5.125	3.062	3.15	17.0	2.75	4.50	MKM 550	M16 x 180	245	42.0
		6146-64-64DM16							M16x2			-----	---		

MOUNTING KITS listed contain carbon steel bolts and Buna N O-Ring. To specify stainless Grade 18-8 bolts, add an SS at the end of the kit number (MK 501SS).

Please note that using stainless steel bolts may reduce the pressure rating of the assembly.

MATERIAL:  
316L Stainless

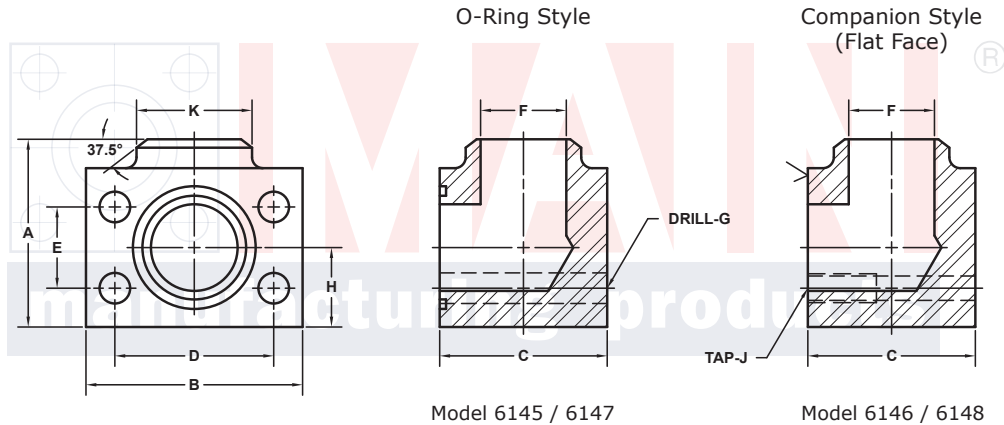

Model 6145 / 6147

Model 6146 / 6148

3181 TRI-PARK DR. GRAND BLANC, MI 48439 800-521-7918 810-953-1380 FAX 810-953-1385 INFO@MAINMFG.COM

## SAE J518 62 SERIES / ISO6162-2 PATTERN

FLANGE SIZE	PIPE SIZE	PART NUMBER	A	B	C	D	E	F	Gmm Jmm	H	K	MOUNTING KIT①			WT
												PART NO.	SCREW SIZE	O-RING	
1½	1¼	6147-24-20DM16	4.00	4.50	2.96	3.125	1.437	.89	17.0	1.62	1.75	MKM 553	M16 x 100	225	10.8
		6148-24-20DM16							M16x2			-----	---		
1½	1½	6147-24-24DM16	3.75	4.50	2.96	3.125	1.437	1.10	17.0	1.62	2.00	MKM 553	M16 x 100	225	10.5
		6148-24-24DM16							M16x2			-----	---		
2	1½	6147-32-24DM20	4.50	5.25	3.46	3.812	1.750	1.10	21.0	2.00	2.00	MKM 554	3/4-10 x 120	228	17.4
		6148-32-24DM20							M20x2.5			-----	---		
2	2	6147-32-32DM20	4.75	5.25	3.46	3.812	1.750	1.50	21.0	2.00	2.50	MKM 554	3/4-10 x 120	228	17.3
		6148-32-32DM20							M20x2.5			-----	---		
2½	2	6147-40-32DM24	5.88	6.88	4.50	4.875	2.312	1.50	25.5	2.50	2.50	MKM 2557	M24 x 150	232	37.8
		6148-40-32DM24							M24x3			-----	---		
2½	2½	6147-40-40DM24	5.88	6.88	4.50	4.875	2.312	1.77	25.5	2.50	3.00	MKM 2557	M24 x 150	232	37.5
		6148-40-40DM24							M24x3			-----	---		
3	3	6147-48-48DM30	7.00	8.50	5.00	6.000	2.812	2.30	32.0	3.00	3.50	MKM 556	M30 x 180	237	61.0
		6148-48-48DM30							M30x3.5			-----	---		

① Order Separately ② 2500 PSI Max ③ 2000 PSI Max ④ 500 PSI Max

⑥ Schedules 40, 80 and 160 also Stocked. Other Pipe and Tube Sizes are Available

NOTE: DIMENSIONS ARE IN INCHES UNLESS OTHERWISE NOTED. † Also Available for M12 Bolts ‡ Also Available for M14 Bolts

© Copyright MAIN Mfg. 2017