

BUTT WELD IN-LINE FLANGES (Pg 1/2)

For Schedule XXS Pipe ⑥

SAE BOLT PATTERN			61 SERIES												
FLANGE SIZE	PIPE SIZE	PART NUMBER	A	B	C	D	E	F	G	H	K	MOUNTING KIT®			WT
									J			PART NO.	SCREW SIZE	O-RING	
1/2	1/2	6121-08-08D	1.50	2.12	1.25	1.500	.688	.25	.34	.38	.88	MK 512	5/16-18 x 1 1/2	210	.8
		5/16-18													
3/4	1/2	6121-12-08D	1.75	2.62	1.25	1.875	.875	.25	.41	.38	.88	MK 1525	3/8-16 x 1 1/2	214	1.1
		3/8-16													
3/4	3/4	6121-12-12D	1.75	2.62	1.25	1.875	.875	.44	.41	.38	1.12	MK 1525	3/8-16 x 1 1/2	214	1.1
		3/8-16													
1	3/4	6121-16-12D	2.00	2.82	1.38	2.062	1.031	.44	.41	.50	1.12	MK 1542	3/8-16 x 1 1/2	219	1.4
		3/8-16													
1	1	6121-16-16D	2.00	2.82	1.38	2.062	1.031	.60	.41	.50	1.38	MK 1542	3/8-16 x 1 1/2	219	1.4
		3/8-16													
1 1/4	1	6121-20-16D	2.50	3.19	1.38	2.312	1.188	.60	.47	.50	1.38	MK 1527	7/16-14 x 1 1/2	222	2.0
		7/16-14													
1 1/4	1 1/4	6121-20-20D	2.50	3.19	1.38	2.312	1.188	.89	.47	.50	1.75	MK 1527	7/16-14 x 1 1/2	222	1.9
		7/16-14													
1 1/4	1 1/2	-----	2.50	3.19	1.50	2.312	1.188	1.10	----	.50	2.00	-----	-----	---	2.1
		6122-20-24D							7/16-14						
1 1/2	1 1/4	6121-24-20D	2.75	3.75	1.50	2.750	1.406	.89	.53	.50	1.75	MK 1547	1/2-13 x 1 3/4	225	2.8
		1/2-13													
1 1/2	1 1/2	6121-24-24D	2.75	3.75	1.50	2.750	1.406	1.10	.53	.50	2.00	MK 1547	1/2-13 x 1 3/4	225	2.7
		1/2-13													
1 1/2	2	-----	3.50	3.75	2.50	2.750	1.406	1.50	----	.75	2.50	-----	-----	---	5.9
		6122-24-32D							1/2-13						

MATERIAL:
316L Stainless

MOUNTING KITS listed contain carbon steel bolts and Buna N O-Ring. To specify stainless Grade 18-8 bolts, add an SS at the end of the kit number (MK 501SS).

Please note that using stainless steel bolts may reduce the pressure rating of the assembly.

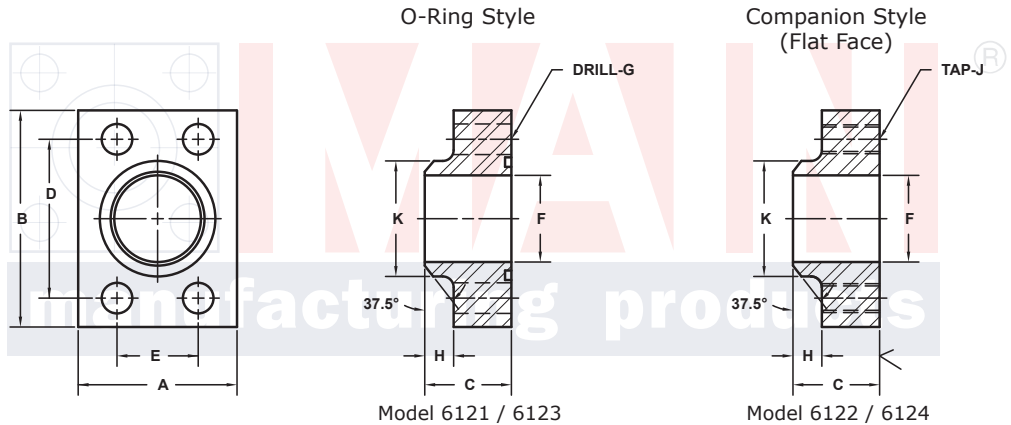

3181 TRI-PARK DR. GRAND BLANC, MI 48439 800-521-7918 810-953-1380 FAX 810-953-1385 INFO@MAINMFG.COM

SAE BOLT PATTERN			62 SERIES												
FLANGE SIZE	PIPE SIZE	PART NUMBER	A	B	C	D	E	F	G	H	K	MOUNTING KIT®			WT
									J			PART NO.	SCREW SIZE	O-RING	
1/2	1/2	6123-08-08D	1.75	2.22	1.25	1.594	.718	.25	.34	.38	.88	MK 512	5/16-18 x 1 1/2	210	.9
		5/16-18													
3/4	1/2	6123-12-08D	2.00	2.81	1.25	2.000	.937	.25	.41	.38	.88	MK 1525	3/8-16 x 1 1/2	214	1.3
		3/8-16													
3/4	3/4	6123-12-12D	2.00	2.81	1.25	2.000	.937	.44	.41	.38	1.12	MK 1525	3/8-16 x 1 1/2	214	1.3
		3/8-16													
1	3/4	6123-16-12D	2.25	3.19	1.50	2.250	1.093	.44	.47	.50	1.12	MK 1504	7/16-14 x 2	219	2.0
		7/16-14													
1	1	6123-16-16D	2.25	3.19	1.50	2.250	1.093	.60	.47	.50	1.38	MK 1504	7/16-14 x 2	219	2.0
		7/16-14													
1 1/4	1	6123-20-16D	2.75	3.75	1.50	2.625	1.250	.60	.53	.50	1.38	MK 2540	1/2-13 x 1 3/4	222	2.8
		1/2-13													
1 1/4	1 1/4	6123-20-20D	2.75	3.75	1.50	2.625	1.250	.89	.53	.50	1.75	MK 2540	1/2-13 x 1 3/4	222	2.8
		1/2-13													
1 1/4	1 1/2	-----	3.00	3.75	1.75	2.625	1.250	1.10	----	.75	2.00	-----	-----	---	3.1
		6124-20-24D							1/2-13						

① Order Separately

⑥ Other Pipe and Tube Sizes are Available

BUTT WELD IN-LINE FLANGES (Pg 2/2)

For Schedule XXS Pipe ⑥

SAE BOLT PATTERN										61 SERIES					
FLANGE SIZE	PIPE SIZE	PART NUMBER	A	B	C	D	E	F	G J	H	K	MOUNTING KIT ^①			WT
												PART NO.	SCREW SIZE	O-RING	
2	1 1/4	6121-32-20D	3.25	4.00	1.50	3.062	1.688	.89	.53	.50	1.75	MK 582	1/2-13 x 1 3/4	228	3.5
		6122-32-20D							1/2-13						
2	1 1/2	6121-32-24D	3.25	4.00	1.50	3.062	1.688	1.10	.53	.50	2.00	MK 582	1/2-13 x 1 3/4	228	3.5
		6122-32-24D							1/2-13						
2	2	6121-32-32D	3.25	4.00	1.75	3.062	1.688	1.50	.53	.75	2.50	MK 582	1/2-13 x 1 3/4	228	3.6
		6122-32-32D							1/2-13						
2 1/2 ^②	2	6121-40-32D	4.00	4.50	2.00	3.500	2.000	1.50	.53	.75	2.50	MK 561	1/2-13 x 2	232	6.1
		6122-40-32D							1/2-13						
2 1/2 ^②	2 1/2	6121-40-40D	4.00	4.50	2.00	3.500	2.000	1.77	.53	.75	3.00	MK 561	1/2-13 x 2	232	6.0
		6122-40-40D							1/2-13						
3 ^③	2 1/2	6121-48-40D	4.50	5.31	2.25	4.188	2.438	1.77	.66	.75	3.00	MK 585	5/8-11 x 2 1/2	237	9.5
		6122-48-40D							5/8-11						
3 ^③	3	6121-48-48D	4.50	5.31	2.25	4.188	2.438	2.30	.66	.75	3.50	MK 585	5/8-11 x 2 1/2	237	8.8
		6122-48-48D							5/8-11						
3 1/2 ^④	3	6121-56-48D	5.00	6.00	1.75	4.750	2.750	2.30	.66	.75	3.50	MK 1571	5/8-11 x 2	241	7.9
		6122-56-48D							5/8-11						
3 1/2 ^④	3 1/2	6121-56-56D	5.00	6.00	1.75	4.750	2.750	2.73	.66	.75	4.00	MK 1571	5/8-11 x 2	241	7.6
		6122-56-56D							5/8-11						
4 ^④	3	6121-64-48D	5.50	6.38	1.75	5.125	3.062	2.30	.66	.75	3.50	MK 1572	5/8-11 x 2	245	9.3
		6122-64-48D							5/8-11						
4 ^④	4	6121-64-64D	5.50	6.38	1.75	5.125	3.062	3.15	.66	.75	4.50	MK 1572	5/8-11 x 2	245	8.7
		6122-64-64D							5/8-11						

MOUNTING KITS listed contain carbon steel bolts and Buna N O-Ring. To specify stainless Grade 18-8 bolts, add an SS at the end of the kit number (MK 501SS).

Please note that using stainless steel bolts may reduce the pressure rating of the assembly.

MATERIAL:
316L Stainless

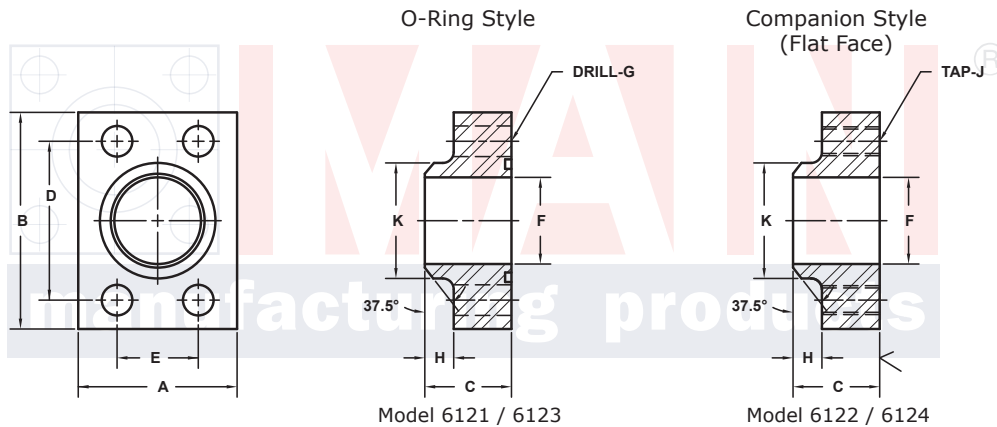

Model 6121 / 6123

Model 6122 / 6124

3181 TRI-PARK DR. GRAND BLANC, MI 48439 800-521-7918 810-953-1380 FAX 810-953-1385 INFO@MAINMFG.COM

SAE BOLT PATTERN										62 SERIES					
FLANGE SIZE	PIPE SIZE	PART NUMBER	A	B	C	D	E	F	G J	H	K	MOUNTING KIT ^①			WT
												PART NO.	SCREW SIZE	O-RING	
1 1/2	1 1/4	6123-24-20D	3.25	4.50	1.50	3.125	1.437	.89	.66	.50	1.75	MK 562	5/8-11 x 2	225	3.9
		6124-24-20D							5/8-11						
1 1/2	1 1/2	6123-24-24D	3.25	4.50	1.50	3.125	1.437	1.10	.66	.50	2.00	MK 562	5/8-11 x 2	225	3.9
		6124-24-24D							5/8-11						
1 1/2	2	-----	4.00	4.50	2.00	3.125	1.437	1.50	---	.75	2.50	-----	-----	---	6.0
		6124-24-32D							5/8-11						
2	1 1/2	6123-32-24D	4.00	5.25	1.75	3.812	1.750	1.10	.78	.50	2.00	MK 1548	3/4-10 x 2 1/2	228	6.9
		6124-32-24D							3/4-10						
2	2	6123-32-32D	4.00	5.25	2.00	3.812	1.750	1.50	.78	.75	2.50	MK 1548	3/4-10 x 2 1/2	228	6.9
		6124-32-32D							3/4-10						
2 1/2	2	6123-40-32D	5.00	6.88	2.50	4.875	2.312	1.50	.94	.75	2.50	MK 5535	7/8-9 x 3	232	15.8
		6124-40-32D							7/8-9						
2 1/2	2 1/2	6123-40-40D	5.00	6.88	2.50	4.875	2.312	1.77	.94	.75	3.00	MK 5535	7/8-9 x 3	232	15.7
		6124-40-40D							7/8-9						
3	3	6123-48-48D	6.00	8.50	3.00	6.000	2.812	2.30	1.19	.88	3.50	MK 1776	1 1/8-7 x 4	237	27.4
		6124-48-48D							1 1/8-7						

① Order Separately ② 2500 PSI Max ③ 2000 PSI Max ④ 500 PSI Max

⑥ Other Pipe and Tube Sizes are Available