

FLANGED BRANCH TEE FLANGES

SAE J518 61 SERIES / ISO6162-1 PATTERN

BRANCH SIZE	RUN SIZE	PART NUMBER	A	B	C	D	E	F	Gmm	H	K	MOUNTING KIT®			WT
									Jmm			PART NO.	SCREW SIZE	O-RING	
1/2	1/2	6575-08M8-08DM8	3.00	2.12	2.25	1.500	.688	.50	8.5	.78	1.50	MKM	M8 x 70	210	3.6
		M8x1.25							-----			---			
3/4	3/4	6185-12M-12DM	2.75	2.62	2.25	1.875	.875	.75	10.5	1.03	1.38	MKM 576	M10 x 70	214	3.6
		M10x1.5							-----			---			
1	1	6185-16M-16DM	3.00	2.82	2.50	2.062	1.031	1.00	10.5	1.16	1.50	MKM 577	M10 x 80	219	4.6
		M10x1.5							-----			---			
1 1/4	1 1/4	6185-20M†-20DM†	3.75	3.19	3.25	2.312	1.188	1.25	10.5	1.38	1.88	MKM 4597	M10 x 90	222	9.0
		M10x1.5							-----			---			
1 1/2	1 1/2	6185-24M‡-24DM‡	4.00	3.75	3.50	2.750	1.406	1.50	13.0	1.62	2.00	MKM 5549	M12 x 110	225	11.2
		M12x1.75							-----			---			
2	2	6185-32M‡-32DM‡	4.25	4.00	4.00	3.062	1.688	1.94	13.0	1.91	2.12	MKM 3550	M12 x 120	228	13.8
		M12x1.75							-----			---			
2 1/2 ^②	2 1/2	6185-40M‡-40DM‡	4.50	4.50	4.50	3.500	2.000	2.44	13.0	2.14	2.25	MKM 4529	M12 x 130	232	17.0
		M12x1.75							-----			---			
3 ^③	3	6185-48M-48DM	5.50	5.31	5.50	4.188	2.438	2.94	17.0	2.58	2.75	MKM 594	M16 x 160	237	29.9
		M16x2							-----			---			
3 1/2 ^④	3 1/2	6185-56M-56DM	6.00	6.00	6.00	4.750	2.750	3.44	17.0	3.00	3.00	MKM 1589	M16 x 180	241	38.0
		M16x2							-----			---			
4 ^④	4	6185-64M-64DM	6.00	6.38	6.00	5.125	3.062	3.94	17.0	2.81	3.00	MKM 550	M16 x 180	245	35.8
		M16x2							-----			---			
5 ^④	5	6185-80M-80DM				6.000	3.625		17.0			MKM	M16 x	253	
		M16x2							-----			---			

MATERIAL:
316L Stainless

MOUNTING KITS listed contain carbon steel bolts and Buna N O-Ring. To specify stainless Grade 18-8 bolts, add an SS at the end of the kit number (MK 501SS).

Please note that using stainless steel bolts may reduce the pressure rating of the assembly.

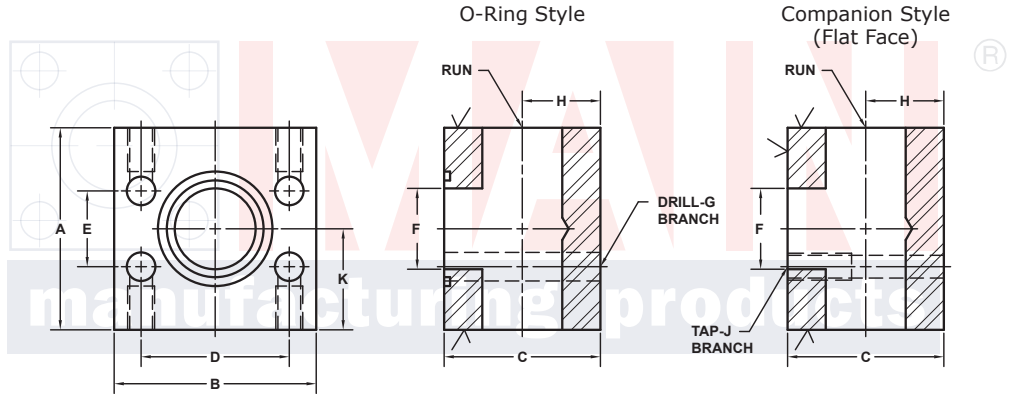

Model 6185 / 6187

Model 6186 / 6188

3181 TRI-PARK DR. GRAND BLANC, MI 48439 800-521-7918 810-953-1380 FAX 810-953-1385 INFO@MAINMFG.COM

SAE J518 62 SERIES / ISO6162-2 PATTERN

BRANCH SIZE	RUN SIZE	PART NUMBER	A	B	C	D	E	F	Gmm	H	K	MOUNTING KIT®			WT
									Jmm			PART NO.	SCREW SIZE	O-RING	
1/2	1/2	6187-08M8-08DM8	2.50	2.22	2.00	1.594	.718	.50	8.5	.94	1.25	MKM 575	M8 x 60	210	2.7
		M8x1.25							-----			---			
3/4	3/4	6187-12M-12DM	3.00	2.81	2.50	2.000	.937	.75	10.5	1.19	1.50	MKM 595	M10 x 80	214	5.1
		M10x1.5							-----			---			
1	1	6187-16M-16DM	3.50	3.19	3.00	2.250	1.093	1.00	12.5	1.38	1.75	MKM 596	M12 x 100	219	7.7
		M12x1.75							-----			---			
1 1/4	1 1/4	6187-20M‡-20DM‡	4.00	3.75	3.50	2.625	1.250	1.25	13.0	1.62	2.00	MKM 5548	M12 x 110	222	11.9
		M12x1.75							-----			---			
1 1/2	1 1/2	6187-24M-24DM	4.50	4.50	4.00	3.125	1.437	1.50	17.0	1.88	2.25	MKM 597	M16 x 130	225	17.8
		M16x2							-----			---			
2	2	6187-32M-32DM	5.00	5.25	5.00	3.812	1.750	1.94	21.0	2.25	2.50	MKM 5554	M20 x 160	228	27.8
		M20x2.5							-----			---			
2 1/2	2 1/2	6187-40M-40DM	7.00	7.00	6.00	4.875	2.312	2.44	25.5	2.50	3.50	MKM	M24 x	232	64.3
		M24x3							-----			---			
3	3	6187-48M-48DM	9.00	8.50	7.00	6.000	2.812	2.94	32.0	3.00	4.50	MKM	M30 x	237	116
		M30x3.5							-----			---			

① Order Separately ② 2500 PSI Max ③ 2000 PSI Max ④ 500 PSI Max