

BUTT WELD FLANGED HEADS

For Schedule 160 Pipe ⑥

61 SERIES

FLANGE SIZE	PIPE SIZE	PART NUMBER	A	B	C	D	E	F	L	O-RING NO. ①	WT
1/2	1/2	1257-08-08	1.25	1.188	.92	.265	.59	.47	1.000	210	.2
		1258-08-08							---	---	
3/4	3/4	1257-12-12	1.44	1.500	1.23	.265	.73	.61	1.250	214	.4
		1258-12-12							---	---	
1	1	1257-16-16	1.44	1.750	1.48	.315	.93	.81	1.562	219	.5
		1258-16-16							---	---	
1 1/4	1 1/4	1257-20-20	1.44	2.000	1.69	.315	1.28	1.16	1.750	222	.6
		1258-20-20							---	---	
1 1/2	1 1/2	1257-24-24	1.50	2.375	1.97	.315	1.46	1.34	2.125	225	.7
		1258-24-24							---	---	
2	2	1257-32-32	1.50	2.812	2.44	.375	1.81	1.69	2.500	228	1.1
		1258-32-32							---	---	
2 1/2	2 1/2	1257-40-40	2.00	3.312	2.89	.375	2.24	2.12	3.000	232	1.8
		1258-40-40							---	---	
3	3	1257-48-48	2.12	4.000	3.53	.375	2.75	2.62	3.625	237	2.7
		1258-48-48							---	---	
3 1/2	3 1/2	1257-56-56	1.62	4.500	3.98	.442	3.12	3.00	4.109	241	2.6
		1258-56-56							---	---	
4	4	1257-64-64	1.88	5.000	4.48	.442	3.56	3.44	4.609	245	3.6
		1258-64-64							---	---	

MATERIAL:
Low Carbon Steel

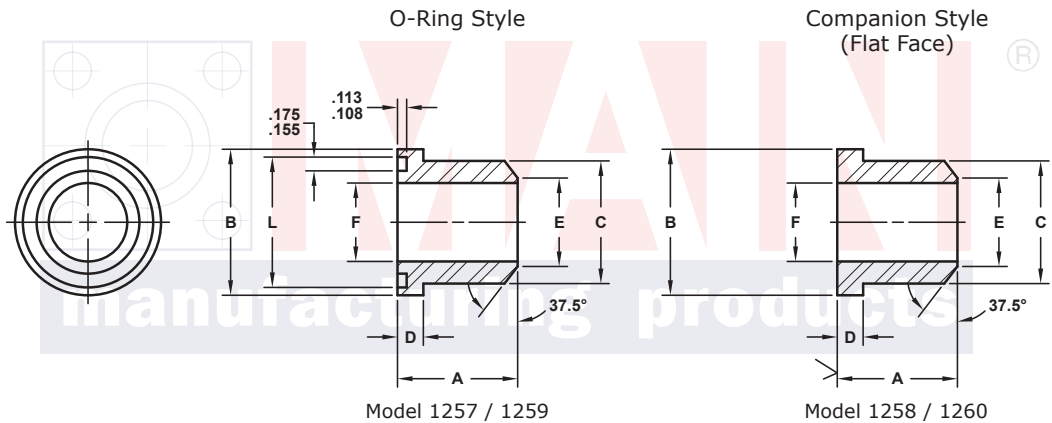

3181 TRI-PARK DR. GRAND BLANC, MI 48439 800-521-7918 810-953-1380 FAX 810-953-1385 INFO@MAINMFG.COM

62 SERIES

FLANGE SIZE	PIPE SIZE	PART NUMBER	A	B	C	D	E	F	L	O-RING NO. ①	WT
1/2	1/2	1259-08-08	1.38	1.250	.92	.305	.59	.47	1.000	210	.2
		1260-08-08							---	---	
3/4	3/4	1259-12-12	1.62	1.625	1.23	.345	.73	.61	1.250	214	.5
		1260-12-12							---	---	
1	1	1259-16-16	1.88	1.875	1.48	.375	.93	.81	1.562	219	.7
		1260-16-16							---	---	
1 1/4	1 1/4	1259-20-20	2.00	2.125	1.69	.405	1.28	1.16	1.750	222	.8
		1260-20-20							---	---	
1 1/2	1 1/2	1259-24-24	2.25	2.500	1.97	.495	1.46	1.34	2.125	225	1.2
		1260-24-24							---	---	
2	2	1259-32-32	2.56	3.125	2.60	.495	1.81	1.69	2.500	228	2.4
		1260-32-32							---	---	

① Order Separately

⑥ Other Pipe and Tube Sizes are Available