

BUTT WELD FLANGED HEADS

For Schedule 40 Pipe ⑥

61 SERIES

FLANGE SIZE	PIPE SIZE	PART NUMBER	A	B	C	D	F ₁	F ₂	L	O-RING NO. ①	WT
1/2	1/2	1249-08-08	1.25	1.188	.92	.265	.53	.62	1.000	210	.2
		1250-08-08							---	---	
3/4	3/4	1249-12-12	1.44	1.500	1.23	.265	.75	.82	1.250	214	.3
		1250-12-12							---	---	
1	1	1249-16-16	1.44	1.750	1.48	.315	.94	1.05	1.562	219	.4
		1250-16-16							---	---	
1 1/4	1 1/4	1249-20-20	1.44	2.000	1.69	.315	1.25	1.38	1.750	222	.5
		1250-20-20							---	---	
1 1/2	1 1/2	1249-24-24	1.50	2.375	1.97	.315	1.50	1.61	2.125	225	.6
		1250-24-24							---	---	
2	2	1249-32-32	1.50	2.812	2.44	.375	1.94	2.06	2.500	228	.8
		1250-32-32							---	---	
2 1/2	2 1/2	1249-40-40	2.00	3.312	2.89	.375	2.47	2.47	3.000	232	1.2
		1250-40-40							---	---	
3	3	1249-48-48	2.12	4.000	3.53	.375	2.90	3.06	3.625	237	2.1
		1250-48-48							---	---	
3 1/2	3 1/2	1249-56-56	1.62	4.500	3.98	.442	3.36	3.54	4.109	241	2.0
		1250-56-56							---	---	
4	4	1249-64-64	1.88	5.000	4.48	.442	3.83	4.02	4.609	245	2.6
		1250-64-64							---	---	

MATERIAL:
Low Carbon Steel

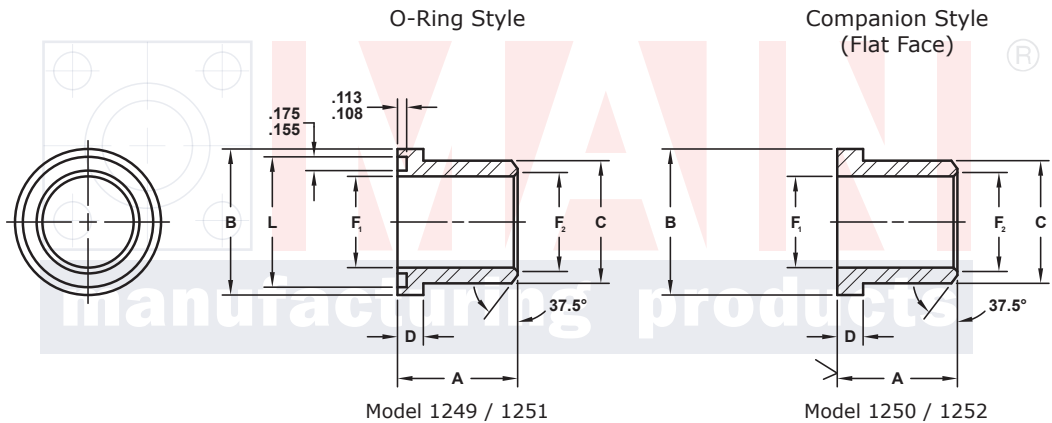

3181 TRI-PARK DR. GRAND BLANC, MI 48439 800-521-7918 810-953-1380 FAX 810-953-1385 INFO@MAINMFG.COM

62 SERIES

FLANGE SIZE	PIPE SIZE	PART NUMBER	A	B	C	D	F ₁	F ₂	L	O-RING NO. ①	WT
1/2	1/2	1251-08-08	1.38	1.250	.92	.305	.53	.62	1.000	210	.2
		1252-08-08							---	---	
3/4	3/4	1251-12-12	1.62	1.625	1.23	.345	.75	.82	1.250	214	.4
		1252-12-12							---	---	
1	1	1251-16-16	1.88	1.875	1.48	.375	.94	1.05	1.562	219	.6
		1252-16-16							---	---	
1 1/4	1 1/4	1251-20-20	2.00	2.125	1.69	.405	1.25	1.38	1.750	222	.7
		1252-20-20							---	---	
1 1/2	1 1/2	1251-24-24	2.25	2.500	1.97	.495	1.50	1.61	2.125	225	1.1
		1252-24-24							---	---	
2	2	1251-32-32	2.56	3.125	2.60	.495	1.94	2.06	2.500	228	1.9
		1252-32-32							---	---	

① Order Separately

⑥ Other Pipe and Tube Sizes are Available