

# BUTT WELD FLANGED HEADS

For Schedule XXS Pipe ⑥

## 61 SERIES

FLANGE SIZE	PIPE SIZE	PART NUMBER	A	B	C	D	E	F	L	O-RING NO. ①	WT
1/2	1/2	1261-08-08	1.25	1.188	.92	.265	.38	.25	1.000	210	.2
		1262-08-08							---	---	
3/4	3/4	1261-12-12	1.44	1.500	1.23	.265	.56	.44	1.250	214	.4
		1262-12-12							---	---	
1	1	1261-16-16	1.44	1.750	1.48	.315	.71	.59	1.562	219	.6
		1262-16-16							---	---	
1 1/4	1 1/4	1261-20-20	1.44	2.000	1.69	.315	1.01	.89	1.750	222	.7
		1262-20-20							---	---	
1 1/2	1 1/2	1261-24-24	1.50	2.375	1.97	.315	1.22	1.10	2.125	225	.9
		1262-24-24							---	---	
2	2	1261-32-32	1.50	2.812	2.44	.375	1.62	1.50	2.500	228	1.2
		1262-32-32							---	---	
2 1/2	2 1/2	1261-40-40	2.00	3.312	2.89	.375	1.89	1.77	3.000	232	2.3
		1262-40-40							---	---	
3	3	1261-48-48	2.12	4.000	3.53	.375	2.42	2.30	3.625	237	3.3
		1262-48-48							---	---	
3 1/2	3 1/2	1261-56-56	1.62	4.500	3.98	.442	2.84	2.72	4.109	241	3.0
		1262-56-56							---	---	
4	4	1261-64-64	1.88	5.000	4.48	.442	3.25	3.12	4.609	245	4.2
		1262-64-64							---	---	

MATERIAL:  
Low Carbon Steel

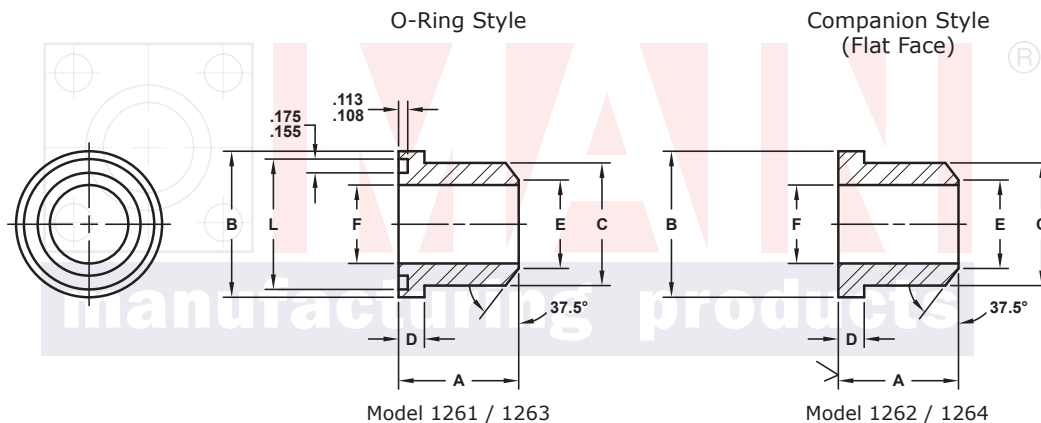

3181 TRI-PARK DR. GRAND BLANC, MI 48439 800-521-7918 810-953-1380 FAX 810-953-1385 INFO@MAINMFG.COM

## 62 SERIES

FLANGE SIZE	PIPE SIZE	PART NUMBER	A	B	C	D	E	F	L	O-RING NO. ①	WT
1/2	1/2	1263-08-08	1.38	1.250	.92	.305	.38	.25	1.000	210	.3
		1264-08-08							---	---	
3/4	3/4	1263-12-12	1.62	1.625	1.23	.345	.56	.44	1.250	214	.5
		1264-12-12							---	---	
1	1	1263-16-16	1.88	1.875	1.48	.375	.71	.59	1.562	219	.8
		1264-16-16							---	---	
1 1/4	1 1/4	1263-20-20	2.00	2.125	1.69	.405	1.01	.89	1.750	222	1.0
		1264-20-20							---	---	
1 1/2	1 1/2	1263-24-24	2.25	2.500	1.97	.495	1.22	1.10	2.125	225	1.5
		1264-24-24							---	---	
2	2	1263-32-32	2.56	3.125	2.60	.495	1.62	1.50	2.500	228	2.7
		1264-32-32							---	---	

① Order Separately

⑥ Other Pipe and Tube Sizes are Available