

# ISO 6149 THREADED ELBOW FLANGES

## SAE J518 61 SERIES / ISO6162-1 PATTERN

FLANGE SIZE	PORT SIZE	PART NUMBER	A	B	C	D	E	F	Gmm	H	K	MOUNTING KIT <sup>①</sup>			WT
									Jmm			PART NO.	SCREW SIZE	O-RING	
1/2	-8	6605-08-08DM8	2.00	2.12	1.44	1.500	.688	.50	8.5	.75	M18x1.5	MKM 541	M8 x 50	210	1.5
		6606-08-08DM8							M8x1.25			-----	---		
3/4	-10	6605-12-10DM10	2.50	2.62	1.70	1.875	.875	.75	10.5	.88	M22x1.5	MKM 542	M10 x 60	214	2.7
		6606-12-10DM10							M10x1.5			-----	---		
3/4	-12	6605-12-12DM10	2.50	2.62	1.70	1.875	.875	.75	10.5	.88	M27x2.0	MKM 542	M10 x 60	214	2.5
		6606-12-12DM10							M10x1.5			-----	---		
1	-12	6605-16-12DM10	3.00	2.82	1.94	2.062	1.031	1.00	10.5	1.00	M27x2.0	MKM 543	M10 x 65	219	3.9
		6606-16-12DM10							M10x1.5			-----	---		
1	-16	6605-16-16DM10	3.00	2.82	1.94	2.062	1.031	1.00	10.5	1.00	M33x2.0	MKM 543	M10 x 65	219	3.7
		6606-16-16DM10							M10x1.5			-----	---		
1 1/4	-20	6605-20-20DM10 <sup>+</sup>	3.50	3.19	2.40	2.312	1.188	1.25	10.5	1.25	M42x2.0	MKM 4532	M10 x 75	222	5.8
		6606-20-20DM10 <sup>+</sup>							M10x1.5			-----	---		
1 1/2	-20	6605-24-20DM12 <sup>+</sup>	4.00	3.75	2.90	2.750	1.406	1.50	13.0	1.38	M42x2.0	MKM 4533	M12 x 90	225	9.2
		6606-24-20DM12 <sup>+</sup>							M12x1.75			-----	---		
1 1/2	-24	6605-24-24DM12 <sup>+</sup>	4.00	3.75	2.90	2.750	1.406	1.50	13.0	1.38	M48x2.0	MKM 4533	M12 x 90	225	9.4
		6606-24-24DM12 <sup>+</sup>							M12x1.75			-----	---		
2	-20	6605-32-20DM12 <sup>+</sup>	4.50	4.00	2.96	3.062	1.688	1.94	13.0	1.62	M42x2.0	MKM 4547	M12 x 90	228	12.3
		6606-32-20DM12 <sup>+</sup>							M12x1.75			-----	---		
2	-24	6605-32-24DM12 <sup>+</sup>	4.50	4.00	2.96	3.062	1.688	1.94	13.0	1.62	M48x2.0	MKM 4547	M12 x 90	228	12.0
		6606-32-24DM12 <sup>+</sup>							M12x1.75			-----	---		
2	-32	6605-32-32DM12 <sup>+</sup>	4.25	4.00	3.40	3.062	1.688	1.94	13.0	1.62	M60x2.0	MKM 4534	M12 x 100	228	11.5
		6606-32-32DM12 <sup>+</sup>							M12x1.75			-----	---		

MOUNTING KITS listed contain carbon steel bolts and Buna N O-Ring. To specify stainless Grade 18-8 bolts, add an SS at the end of the kit number (MK 501SS).

Please note that using stainless steel bolts may reduce the pressure rating of the assembly.

MATERIAL:  
316L Stainless

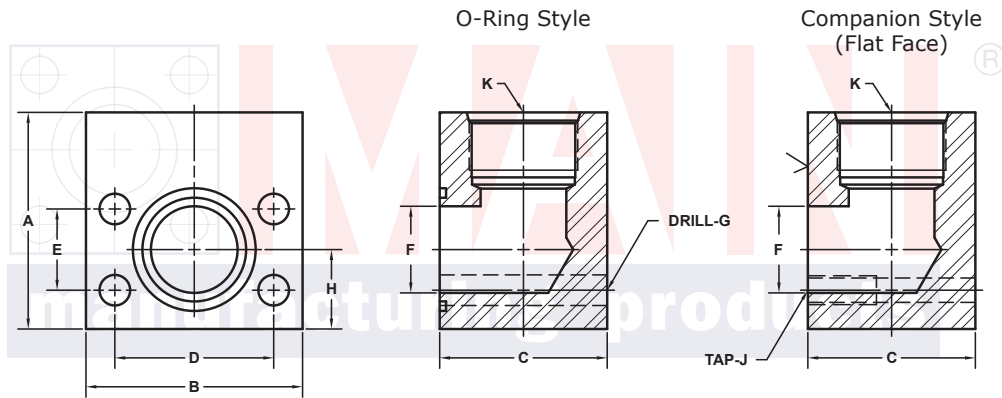

Model 6605 / 6607

Model 6606 / 6608

3181 TRI-PARK DR. GRAND BLANC, MI 48439 800-521-7918 810-953-1380 FAX 810-953-1385 INFO@MAINMFG.COM

## SAE J518 62 SERIES / ISO6162-2 PATTERN

FLANGE SIZE	PORT SIZE	PART NUMBER	A	B	C	D	E	F	Gmm	H	K	MOUNTING KIT <sup>①</sup>			WT
									Jmm			PART NO.	SCREW SIZE	O-RING	
1/2	-8	6607-08-08DM8	2.00	2.22	1.46	1.594	.718	.50	8.5	.88	M18x1.5	MKM 541	M8 x 50	210	1.6
		6608-08-08DM8							M8x1.25			-----	---		
3/4	-10	6607-12-10DM10	2.50	2.81	1.70	2.000	.937	.75	10.5	1.00	M22x1.5	MKM 542	M10 x 60	214	3.0
		6608-12-10DM10							M10x1.5			-----	---		
3/4	-12	6607-12-12DM10	2.50	2.81	1.70	2.000	.937	.75	10.5	1.00	M27x2.0	MKM 542	M10 x 60	214	2.8
		6608-12-12DM10							M10x1.5			-----	---		
1	-12	6607-16-12DM12	3.00	3.19	1.96	2.250	1.093	1.00	12.5	1.12	M27x2.0	MKM 551	M12 x 70	219	4.5
		6608-16-12DM12							M12x1.75			-----	---		
1	-16	6607-16-16DM12	3.00	3.19	1.96	2.250	1.093	1.00	12.5	1.12	M33x2.0	MKM 551	M12 x 70	219	4.3
		6608-16-16DM12							M12x1.75			-----	---		
1 1/4	-20	6607-20-20DM12 <sup>+</sup>	4.00	3.75	2.44	2.625	1.250	1.25	13.0	1.38	M42x2.0	MKM 578	M12 x 80	222	8.3
		6608-20-20DM12 <sup>+</sup>							M12x1.75			-----	---		
1 1/2	-24	6607-24-24DM16	4.00	4.50	2.96	3.125	1.437	1.50	17.0	1.62	M48x2.0	MKM 553	M16 x 100	225	12.0
		6608-24-24DM16							M16x2			-----	---		
2	-32	6607-32-32DM20	5.00	5.25	3.46	3.812	1.750	1.94	21.0	2.00	M60x2.0	MKM 554	M20 x 120	228	19.7
		6608-32-32DM20							M20x2.5			-----	---		

① Order Separately

NOTE: The Pressure Rating of the Assembly Should NOT Exceed the Lower of the Flange Pad or the Fitting. Check the Fitting Manufacturer for Details.

NOTE: DIMENSIONS ARE IN INCHES UNLESS OTHERWISE NOTED. + Also Available for M12 Bolts † Also Available for M14 Bolts

© Copyright MAIN Mfg. 2017