

NPTF THREADED BRANCH TEE FLANGES

SAE BOLT PATTERN			61 SERIES												
FLANGE SIZE	PIPE SIZE	PART NUMBER	A	B	C	D	E	F	G	H	K NPTF	MOUNTING KIT®			WT
									J			PART NO.	SCREW SIZE	O-RING	
1/2	1/2	1153-08-08	2.50	2.12	1.44	1.500	.688	.50	.34	1.25	1/2	MK 541	5/16-18 x 2	210	1.8
		1154-08-08							5/16-18						
3/4	3/4	1153-12-12	3.00	2.62	1.70	1.875	.875	.75	.41	1.50	3/4	MK 542	3/8-16 x 2 1/2	214	3.0
		1154-12-12							3/8-16						
1	3/4	1153-16-12	4.00	2.82	1.94	2.062	1.031	1.00	.41	2.00	3/4	MK 543	3/8-16 x 2 3/4	219	5.1
		1154-16-12							3/8-16						
1	1	1153-16-16	4.00	2.82	1.94	2.062	1.031	1.00	.41	2.00	1	MK 543	3/8-16 x 2 3/4	219	4.8
		1154-16-16							3/8-16						
1 1/4	3/4	1153-20-12	4.50	3.19	2.40	2.312	1.188	1.25	.47	2.25	3/4	MK 578	7/16-14 x 3 1/4	222	8.0
		1154-20-12							7/16-14						
1 1/4	1	1153-20-16	4.50	3.19	2.40	2.312	1.188	1.25	.47	2.25	1	MK 578	7/16-14 x 3 1/4	222	7.7
		1154-20-16							7/16-14						
1 1/4	1 1/4	1153-20-20	4.50	3.19	2.40	2.312	1.188	1.25	.47	2.25	1 1/4	MK 578	7/16-14 x 3 1/4	222	7.3
		1154-20-20							7/16-14						
1 1/2	1 1/4	1153-24-20	4.50	3.75	2.90	2.750	1.406	1.50	.53	2.25	1 1/4	MK 545	1/2-13 x 4	225	12.1
		1154-24-20							1/2-13						
1 1/2	1 1/2	1153-24-24	4.50	3.75	2.90	2.750	1.406	1.50	.53	2.25	1 1/2	MK 545	1/2-13 x 4	225	10.2
		1154-24-24							1/2-13						
2	1 1/2	1153-32-24	5.25	4.00	2.96	3.062	1.688	1.94	.53	2.62	1 1/2	MK 558	1/2-13 x 4	228	13.0
		1154-32-24							1/2-13						
2	2	1153-32-32	5.25	4.00	2.96	3.062	1.688	1.94	.53	2.62	2	MK 558	1/2-13 x 4	228	11.5
		1154-32-32							1/2-13						

MATERIAL:
Low Carbon Steel®

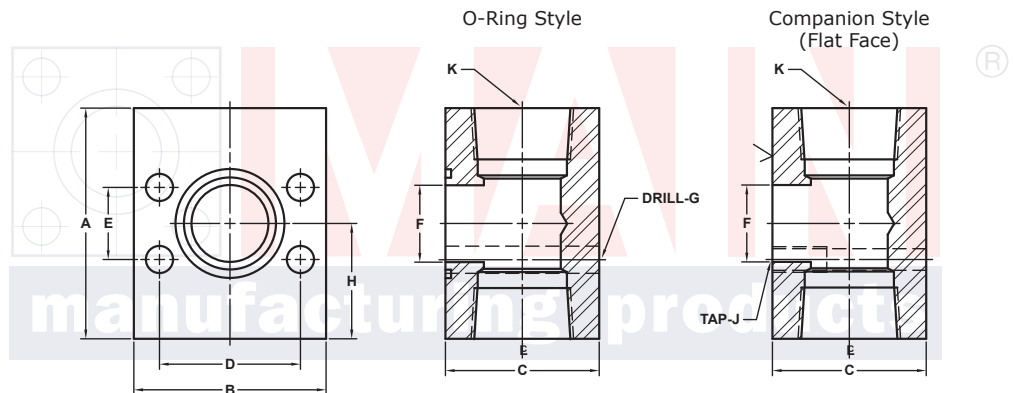

Model 1153 / 1155

Model 1154 / 1156

3181 TRI-PARK DR. GRAND BLANC, MI 48439 800-521-7918 810-953-1380 FAX 810-953-1385 INFO@MAINMFG.COM

SAE BOLT PATTERN			62 SERIES												
FLANGE SIZE	PIPE SIZE	PART NUMBER	A	B	C	D	E	F	G	H	K NPTF	MOUNTING KIT®			WT
									J			PART NO.	SCREW SIZE	O-RING	
1/2	1/2	1155-08-08	2.50	2.22	1.46	1.594	.718	.50	.34	1.25	1/2	MK 541	5/16-18 x 2	210	2.0
		1156-08-08							5/16-18						
3/4	3/4	1155-12-12	3.00	2.81	1.70	2.000	.937	.75	.41	1.50	3/4	MK 542	3/8-16 x 2 1/2	214	3.3
		1156-12-12							3/8-16						
1	1	1155-16-16	4.00	3.19	1.96	2.250	1.093	1.00	.47	2.00	1	MK 551	7/16-14 x 2 3/4	219	5.7
		1156-16-16							7/16-14						
1 1/4	1 1/4	1155-20-20	4.50	3.75	2.44	2.625	1.250	1.25	.53	2.25	1 1/4	MK 552	1/2-13 x 3 1/4	222	9.0
		1156-20-20							1/2-13						
1 1/2	1 1/2	1155-24-24	4.50	4.50	2.96	3.125	1.437	1.50	.66	2.25	1 1/2	MK 553	5/8-11 x 4	225	13.0
		1156-24-24							5/8-11						
1 1/2	2	1155-24-32	5.00	4.50	3.50	3.125	1.437	1.50	.66	2.50	2	MK 1587	5/8-11 x 4 1/2	225	15.8
		1156-24-32							5/8-11						
2	1 1/2	1155-32-24	6.00	5.25	3.46	3.812	1.750	1.94	.78	3.00	1 1/2	MK 554	3/4-10 x 4 1/2	228	24.3
		1156-32-24							3/4-10						
2	2	1155-32-32	6.00	5.25	3.46	3.812	1.750	1.94	.78	3.00	2	MK 554	3/4-10 x 4 1/2	228	22.8
		1156-32-32							3/4-10						

① Order Separately

⑤ May Contain Lead