

# SAE J1926 THREADED IN-LINE FLANGES (Pg 1/2)

SAE BOLT PATTERN										61 SERIES				
FLANGE SIZE	ORB	PART NUMBER	A	B	C	D	E	F	G J	K	MOUNTING KIT®			WT
											PART NO.	SCREW SIZE	O-RING	
1/2	-4	1173-08-04	1.50	2.12	1.25	1.500	.688	.37	.34	7/16-20	MK 501	5/16-18 x 1 1/4	210	1.0
		1174-08-04							5/16-18		-----	---		
1/2	-6	1173-08-06	1.50	2.12	1.25	1.500	.688	.47	.34	9/16-18	MK 501	5/16-18 x 1 1/4	210	1.0
		1174-08-06							5/16-18		-----	---		
1/2	-8	1173-08-08	1.50	2.12	1.25	1.500	.688	.50	.34	3/4-16	MK 501	5/16-18 x 1 1/4	210	.9
		1174-08-08							5/16-18		-----	---		
3/4	-8	1173-12-08	1.75	2.62	1.50	1.875	.875	.66	.41	3/4-16	MK 1525	3/8-16 x 1 1/2	214	1.6
		1174-12-08							3/8-16		-----	---		
3/4	-10	1173-12-10	1.75	2.62	1.50	1.875	.875	.50	.41	7/8-14	MK 1525	3/8-16 x 1 1/2	214	1.5
		1174-12-10							3/8-16		-----	---		
3/4	-12	1173-12-12	1.75	2.62	1.50	1.875	.875	.75	.41	1 1/16-12	MK 1525	3/8-16 x 1 1/2	214	1.4
		1174-12-12							3/8-16		-----	---		
3/4	-16	-----	2.00	2.62	2.50	1.875	.875	.75	---	1 5/16-12	-----	-----	---	3.0
		1174-12-16							3/8-16		-----	---		
1	-12	1173-16-12	2.00	2.82	1.50	2.062	1.031	.94	.41	1 1/16-12	MK 1542	3/8-16 x 1 1/2	219	1.9
		1174-16-12							3/8-16		-----	---		
1	-14	1173-16-14	2.00	2.82	1.50	2.062	1.031	.75	.41	1 3/16-12	MK 1542	3/8-16 x 1 1/2	219	1.8
		1174-16-14							3/8-16		-----	---		
1	-16	1173-16-16	2.00	2.82	1.50	2.062	1.031	1.00	.41	1 5/16-12	MK 1542	3/8-16 x 1 1/2	219	1.7
		1174-16-16							3/8-16		-----	---		
1	-20	-----	2.50	3.00	3.00	2.062	1.031	1.00	---	1 5/8-12	-----	-----	---	5.2
		1174-16-20							3/8-16		-----	---		

MATERIAL:  
Low Carbon Steel<sup>®</sup>

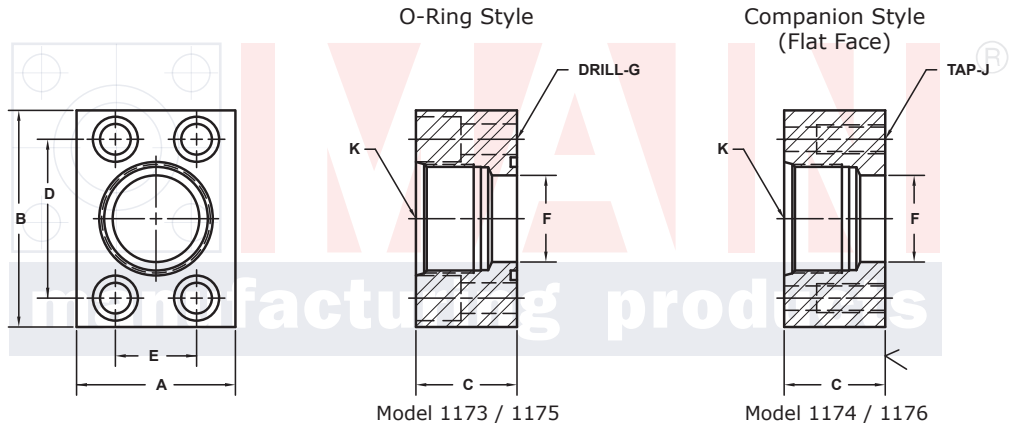
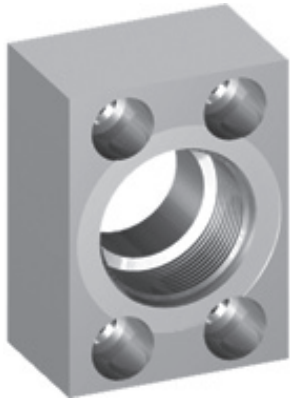

Model 1173 / 1175

Model 1174 / 1176

3181 TRI-PARK DR. GRAND BLANC, MI 48439 800-521-7918 810-953-1380 FAX 810-953-1385 INFO@MAINMFG.COM

SAE BOLT PATTERN										62 SERIES				
FLANGE SIZE	ORB	PART NUMBER	A	B	C	D	E	F	G J	K	MOUNTING KIT®			WT
											PART NO.	SCREW SIZE	O-RING	
1/2	-6	1175-08-06	1.75	2.22	1.25	1.594	.718	.47	.34	9/16-18	MK 501	5/16-18 x 1 1/4	210	1.2
		1176-08-06							5/16-18		-----	---		
1/2	-8	1175-08-08	1.75	2.22	1.25	1.594	.718	.50	.34	3/4-16	MK 501	5/16-18 x 1 1/4	210	1.1
		1176-08-08							5/16-18		-----	---		
3/4	-8	1175-12-08	2.00	2.81	1.50	2.000	.937	.66	.41	3/4-16	MK 1525	3/8-16 x 1 1/2	214	2.0
		1176-12-08							3/8-16		-----	---		
3/4	-10	1175-12-10	2.00	2.81	1.50	2.000	.937	.50	.41	7/8-14	MK 1525	3/8-16 x 1 1/2	214	1.9
		1176-12-10							3/8-16		-----	---		
3/4	-12	1175-12-12	2.00	2.81	1.50	2.000	.937	.75	.41	1 1/16-12	MK 1525	3/8-16 x 1 1/2	214	1.8
		1176-12-12							3/8-16		-----	---		
1	-12	1175-16-12	2.25	3.19	1.50	2.250	1.093	.94	.47	1 1/16-12	MK 1529	7/16-14 x 1 1/2	219	2.5
		1176-16-12							7/16-14		-----	---		
1	-14	1175-16-14	2.25	3.19	1.50	2.250	1.093	.75	.47	1 3/16-12	MK 1529	7/16-14 x 1 1/2	219	2.4
		1176-16-14							7/16-14		-----	---		
1	-16	1175-16-16	2.25	3.19	1.50	2.250	1.093	1.00	.47	1 5/16-12	MK 1529	7/16-14 x 1 1/2	219	2.3
		1176-16-16							7/16-14		-----	---		

① Order Separately

® May Contain Lead

NOTE: The Pressure Rating of the Assembly Should NOT Exceed the Lower of the Flange Pad or the Fitting. Check the Fitting Manufacturer for Details.

# SAE J1926 THREADED IN-LINE FLANGES (Pg 2/2)

SAE BOLT PATTERN										61 SERIES				
FLANGE SIZE	ORB	PART NUMBER	A	B	C	D	E	F	G	K	MOUNTING KIT®			WT
									J		PART NO.	SCREW SIZE	O-RING	
<b>1 1/4</b>	<b>-16</b>	1173-20-16	2.50	3.19	1.50	2.312	1.188	1.20	.47	1 5/16-12	MK 1527	7/16-14 x 1 1/2	222	2.6
		1174-20-16							7/16-14		-----	---		
<b>1 1/4</b>	<b>-20</b>	1173-20-20	2.50	3.19	1.50	2.312	1.188	1.25	.47	1 5/8-12	MK 1527	7/16-14 x 1 1/2	222	2.3
		1174-20-20							7/16-14		-----	---		
<b>1 1/4</b>	<b>-24</b>	-----	3.00	3.19	3.00	2.312	1.188	1.25	----	1 7/8-12	-----	-----	---	6.4
		1174-20-24							7/16-14		-----	---		
<b>1 1/2</b>	<b>-20</b>	1173-24-20	2.75	3.75	1.75	2.750	1.406	1.50	.53	1 5/8-12	MK 1547	1/2-13 x 1 3/4	225	3.8
		1174-24-20							1/2-13		-----	---		
<b>1 1/2</b>	<b>-24</b>	1173-24-24	2.75	3.75	1.75	2.750	1.406	1.50	.53	1 7/8-12	MK 1547	1/2-13 x 1 3/4	225	3.5
		1174-24-24							1/2-13		-----	---		
<b>1 1/2</b>	<b>-32</b>	-----	3.50	3.75	3.50	2.750	1.406	1.50	----	2 1/2-12	-----	-----	---	9.9
		1174-24-32							1/2-13		-----	---		
<b>2</b>	<b>-20</b>	1173-32-20	3.25	4.00	1.75	3.062	1.688	1.50	.53	1 5/8-12	MK 582	1/2-13 x 1 3/4	228	5.2
		1174-32-20							1/2-13		-----	---		
<b>2</b>	<b>-24</b>	1173-32-24	3.25	4.00	1.75	3.062	1.688	1.75	.53	1 7/8-12	MK 582	1/2-13 x 1 3/4	228	4.8
		1174-32-24							1/2-13		-----	---		
<b>2</b>	<b>-32</b>	-----	3.25	4.00	1.75	3.062	1.688	1.94	----	2 1/2-12	-----	-----	---	3.9
		1174-32-32							1/2-13		-----	---		
<b>2 1/2</b> ②	<b>-24</b>	1173-40-24	4.00	4.50	1.75	3.500	2.000	1.75	.53	1 7/8-12	MK 1528	1/2-13 x 1 3/4	232	7.4
		1174-40-24							1/2-13		-----	---		
<b>2 1/2</b> ②	<b>-32</b>	1173-40-32	4.00	4.50	1.75	3.500	2.000	2.32	.53	2 1/2-12	MK 1528	1/2-13 x 1 3/4	232	6.3
		1174-40-32							1/2-13		-----	---		

**MATERIAL:**  
**Low Carbon Steel**®

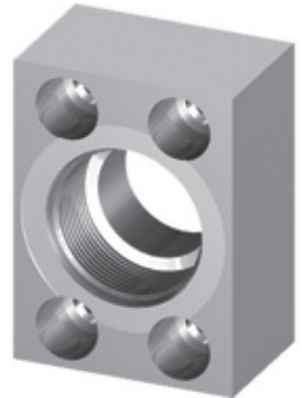
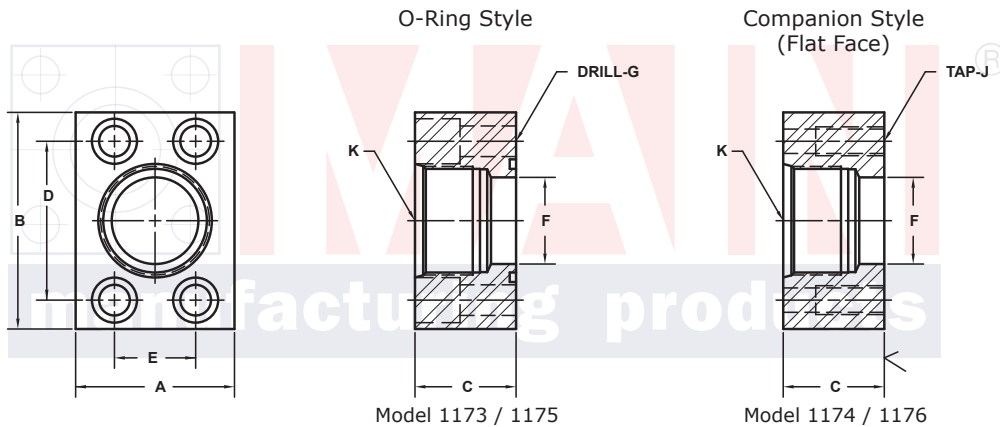

3181 TRI-PARK DR. GRAND BLANC, MI 48439 800-521-7918 810-953-1380 FAX 810-953-1385 INFO@MAINMFG.COM

SAE BOLT PATTERN										62 SERIES				
FLANGE SIZE	ORB	PART NUMBER	A	B	C	D	E	F	G	K	MOUNTING KIT®			WT
									J		PART NO.	SCREW SIZE	O-RING	
<b>1 1/4</b>	<b>-16</b>	1175-20-16	3.00	3.75	1.50	2.625	1.250	1.20	.53	1 5/16-12	MK 1523	1/2-13 x 1 1/2	222	4.0
		1176-20-16							1/2-13		-----	---		
<b>1 1/4</b>	<b>-20</b>	1175-20-20	3.00	3.75	1.50	2.625	1.250	1.25	.53	1 5/8-12	MK 1523	1/2-13 x 1 1/2	222	3.7
		1176-20-20							1/2-13		-----	---		
<b>1 1/2</b>	<b>-16</b>	1175-24-16	3.25	4.50	1.75	3.125	1.437	1.20	.66	1 5/16-12	MK 1544	5/8-11 x 1 3/4	225	6.1
		1176-24-16							5/8-11		-----	---		
<b>1 1/2</b>	<b>-20</b>	1175-24-20	3.25	4.50	1.75	3.125	1.437	1.50	.66	1 5/8-12	MK 1544	5/8-11 x 1 3/4	225	5.8
		1176-24-20							5/8-11		-----	---		
<b>1 1/2</b>	<b>-24</b>	1175-24-24	3.25	4.50	1.75	3.125	1.437	1.50	.66	1 7/8-12	MK 1544	5/8-11 x 1 3/4	225	5.5
		1176-24-24							5/8-11		-----	---		
<b>2</b>	<b>-20</b>	1175-32-20	4.00	5.25	1.75	3.812	1.750	1.50	.78	1 5/8-12	MK 563	3/4-10 x 2	228	8.8
		1176-32-20							3/4-10		-----	---		
<b>2</b>	<b>-24</b>	1175-32-24	4.00	5.25	1.75	3.812	1.750	1.75	.78	1 7/8-12	MK 563	3/4-10 x 2	228	8.4
		1176-32-24							3/4-10		-----	---		
<b>2</b>	<b>-32</b>	1175-32-32	4.00	5.25	1.75	3.812	1.750	1.94	.78	2 1/2-12	MK 563	3/4-10 x 2	228	7.5
		1176-32-32							3/4-10		-----	---		

① Order Separately

② 2500 PSI Max

⑤ May Contain Lead

**NOTE:** The Pressure Rating of the Assembly Should NOT Exceed the Lower of the Flange Pad or the Fitting. Check the Fitting Manufacturer for Details.