

SAE J1926 THREADED RUN TEE FLANGES

SAE BOLT PATTERN			61 SERIES									
FLANGE SIZE	ORB	PART NUMBER	A	B	C	D	E	F	K	L	O-RING ^①	WT
1/2	-8	6201-08-08D	2.00	2.12	1.44	1.500	.688	.50	3/4-16	1.000	210	1.5
		6202-08-08D								---	---	
1/2	-12	6201-08-12D	2.75	2.12	1.75	1.500	.688	.50	1 1/16-12	1.000	210	2.3
		6202-08-12D								---	---	
3/4	-8	6201-12-08D	2.50	2.62	1.70	1.875	.875	.75	3/4-16	1.250	214	2.7
		6202-12-08D								---	---	
3/4	-10	6201-12-10D	2.50	2.62	1.70	1.875	.875	.75	7/8-14	1.250	214	2.7
		6202-12-10D								---	---	
3/4	-12	6201-12-12D	2.50	2.62	1.70	1.875	.875	.75	1 1/16-12	1.250	214	2.5
		6202-12-12D								---	---	
1	-12	6201-16-12D	3.00	2.82	1.94	2.062	1.031	1.00	1 1/16-12	1.562	219	3.8
		6202-16-12D								---	---	
1	-14	6201-16-14D	3.00	2.82	1.94	2.062	1.031	1.00	1 3/16-12	1.562	219	3.7
		6202-16-14D								---	---	
1	-16	6201-16-16D	3.00	2.82	1.94	2.062	1.031	1.00	1 5/16-12	1.562	219	3.5
		6202-16-16D								---	---	
1 1/4	-20	6201-20-20D	3.50	3.19	2.40	2.312	1.188	1.25	1 5/8-12	1.750	222	5.7
		6202-20-20D								---	---	
1 1/2	-24	6201-24-24D	4.00	3.75	2.90	2.750	1.406	1.50	1 7/8-12	2.125	225	10.0
		6202-24-24D								---	---	
2	-32	6201-32-32D	4.25	4.00	3.94	3.062	1.688	1.94	2 1/2-12	2.500	228	14.0
		6202-32-32D								---	---	

MATERIAL:
316L Stainless

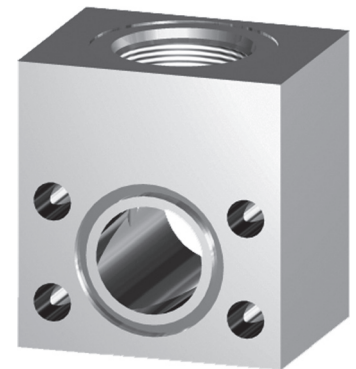
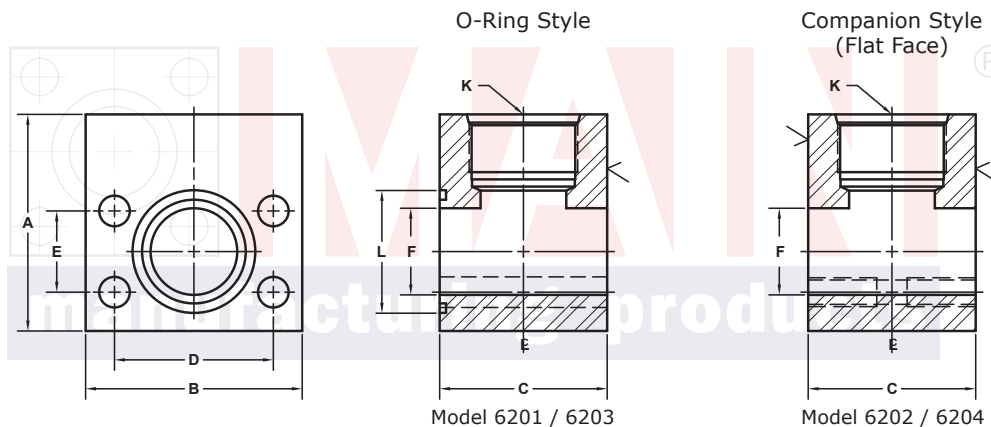

3181 TRI-PARK DR. GRAND BLANC, MI 48439 800-521-7918 810-953-1380 FAX 810-953-1385 INFO@MAINMFG.COM

SAE BOLT PATTERN			62 SERIES									
FLANGE SIZE	ORB	PART NUMBER	A	B	C	D	E	F	K	L	O-RING ^①	WT
1/2	-8	6203-08-08D	2.00	2.22	1.46	1.594	.718	.50	3/4-16	1.000	210	1.7
		6204-08-08D								---	---	
3/4	-10	6203-12-10D	2.50	2.81	1.70	2.000	.937	.75	7/8-14	1.250	214	3.0
		6204-12-10D								---	---	
3/4	-12	6203-12-12D	2.50	2.81	1.70	2.000	.937	.75	1 1/16-12	1.250	214	2.7
		6204-12-12D								---	---	
1	-14	6203-16-14D	3.00	3.19	1.96	2.250	1.093	1.00	1 3/16-12	1.562	219	4.5
		6204-16-14D								---	---	
1	-16	6203-16-16D	3.00	3.19	1.96	2.250	1.093	1.00	1 5/16-12	1.562	219	4.5
		6204-16-16D								---	---	
1 1/4	-20	6203-20-20D	4.00	3.75	2.44	2.625	1.250	1.25	1 5/8-12	1.750	222	7.8
		6204-20-20D								---	---	
1 1/2	-24	6203-24-24D	4.00	4.50	2.96	3.125	1.437	1.50	1 7/8-12	2.125	225	12.0
		6204-24-24D								---	---	
2	-32	6203-32-32D	5.00	5.25	3.94	3.812	1.750	1.94	2 1/2-12	2.500	228	20.2
		6204-32-32D								---	---	

① Includes Buna-N O-Ring

NOTE: The Pressure Rating of the Assembly Should NOT Exceed the Lower of the Flange Pad or the Fitting. Check the Fitting Manufacturer for Details.