

# SAE J1926 THREADED RUN TEE FLANGES

## SAE J518 61 SERIES / ISO6162-1 PATTERN

FLANGE SIZE	ORB	PART NUMBER	A	B	C	D	E	F	K	L	O-RING <sup>①</sup>	WT
1/2	-8	1201-08-08M8	2.00	2.12	1.44	1.500	.688	.50	3/4-16	1.000	210	1.5
		1202-08-08M8								---	---	
1/2	-12	1201-08-12M8	2.75	2.12	1.75	1.500	.688	.50	1 1/16-12	1.000	210	2.3
		1202-08-12M8								---	---	
3/4	-8	1201-12-08M10	2.50	2.62	1.70	1.875	.875	.75	3/4-16	1.250	214	2.7
		1202-12-08M10								---	---	
3/4	-10	1201-12-10M10	2.50	2.62	1.70	1.875	.875	.75	7/8-14	1.250	214	2.7
		1202-12-10M10								---	---	
3/4	-12	1201-12-12M10	2.50	2.62	1.70	1.875	.875	.75	1 1/16-12	1.250	214	2.5
		1202-12-12M10								---	---	
1	-12	1201-16-12M10	3.00	2.82	1.94	2.062	1.031	1.00	1 1/16-12	1.562	219	3.8
		1202-16-12M10								---	---	
1	-14	1201-16-14M10	3.00	2.82	1.94	2.062	1.031	1.00	1 3/16-12	1.562	219	3.7
		1202-16-14M10								---	---	
1	-16	1201-16-16M10	3.00	2.82	1.94	2.062	1.031	1.00	1 5/16-12	1.562	219	3.5
		1202-16-16M10								---	---	
1 1/4	-20	1201-20-20M10 <sup>+</sup>	3.50	3.19	2.40	2.312	1.188	1.25	1 5/8-12	1.750	222	5.7
		1202-20-20M10 <sup>+</sup>								---	---	
1 1/2	-24	1201-24-24M12 <sup>‡</sup>	4.00	3.75	2.90	2.750	1.406	1.50	1 7/8-12	2.125	225	10.0
		1202-24-24M12 <sup>‡</sup>								---	---	
2	-32	1201-32-32M12 <sup>‡</sup>	4.25	4.00	3.94	3.062	1.688	1.94	2 1/2-12	2.500	228	14.0
		1202-32-32M12 <sup>‡</sup>								---	---	

MATERIAL:  
Low Carbon Steel<sup>®</sup>

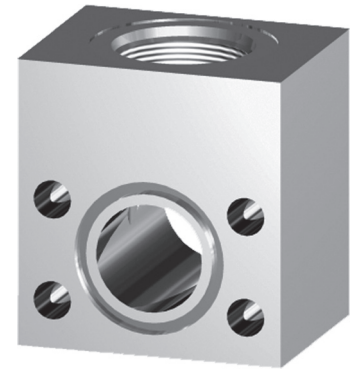
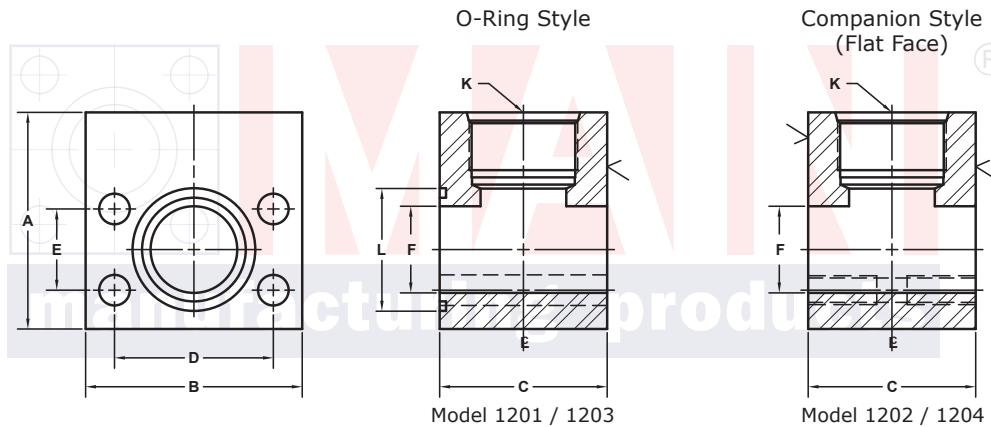

3181 TRI-PARK DR. GRAND BLANC, MI 48439 800-521-7918 810-953-1380 FAX 810-953-1385 INFO@MAINMFG.COM

## SAE J518 62 SERIES / ISO6162-2 PATTERN

FLANGE SIZE	ORB	PART NUMBER	A	B	C	D	E	F	K	L	O-RING <sup>①</sup>	WT
1/2	-8	1203-08-08M8	2.00	2.22	1.46	1.594	.718	.50	3/4-16	1.000	210	1.7
		1204-08-08M8								---	---	
3/4	-10	1203-12-10M10	2.50	2.81	1.70	2.000	.937	.75	7/8-14	1.250	214	3.0
		1204-12-10M10								---	---	
3/4	-12	1203-12-12M10	2.50	2.81	1.70	2.000	.937	.75	1 1/16-12	1.250	214	2.7
		1204-12-12M10								---	---	
1	-14	1203-16-14M12	3.00	3.19	1.96	2.250	1.093	1.00	1 3/16-12	1.562	219	4.5
		1204-16-14M12								---	---	
1	-16	1203-16-16M12	3.00	3.19	1.96	2.250	1.093	1.00	1 5/16-12	1.562	219	4.5
		1204-16-16M12								---	---	
1 1/4	-20	1203-20-20M12 <sup>‡</sup>	4.00	3.75	2.44	2.625	1.250	1.25	1 5/8-12	1.750	222	7.8
		1204-20-20M12 <sup>‡</sup>								---	---	
1 1/2	-24	1203-24-24M16	4.00	4.50	2.96	3.125	1.437	1.50	1 7/8-12	2.125	225	12.0
		1204-24-24M16								---	---	
2	-32	1203-32-32M20	5.00	5.25	3.94	3.812	1.750	1.94	2 1/2-12	2.500	228	20.2
		1204-32-32M20								---	---	

① Includes Buna-N O-Ring

® May Contain Lead

**NOTE:** The Pressure Rating of the Assembly Should NOT Exceed the Lower of the Flange Pad or the Fitting. Check the Fitting Manufacturer for Details.

NOTE: DIMENSIONS ARE IN INCHES UNLESS OTHERWISE NOTED. + Also Available for M12 Bolts ‡ Also Available for M14 Bolts

© Copyright MAIN Mfg. 2017