

# SOCKET WELD PIPE IN-LINE FLANGES

WITH -4 ORB (7/16-20) GAUGE PORT

SAE BOLT PATTERN										61 SERIES					
FLANGE SIZE	PIPE SIZE	PART NUMBER	A	B	C	D	E	F	G J	H	K	MOUNTING KIT®			WT
												PART NO.	SCREW SIZE	O-RING	
1/2	1/2	8101-08-08D	1.50	2.12	1.25	1.500	.688	.50	.34	.38	.860	MK 519	5/16-18 x 1 3/4	210	.7
		8102-08-08D							5/16-18						
3/4	3/4	8101-12-12D	1.75	2.62	1.25	1.875	.875	.75	.41	.50	1.070	MK 520	3/8-16 x 2	214	1.2
		8102-12-12D							3/8-16						
1	1	8101-16-16D	2.00	2.82	1.25	2.062	1.031	1.00	.41	.50	1.335	MK 1501	3/8-16 x 2	219	1.5
		8102-16-16D							3/8-16						
1 1/4	1 1/4	8101-20-20D	2.50	3.19	1.25	2.312	1.188	1.25	.47	.50	1.680	MK 1502	7/16-14 x 2	222	2.0
		8102-20-20D							7/16-14						
1 1/2	1 1/2	8101-24-24D	2.75	3.75	1.25	2.750	1.406	1.50	.53	.50	1.920	MK 505	1/2-13 x 2	225	2.5
		8102-24-24D							1/2-13						
2	2	8101-32-32D	3.25	4.00	1.50	3.062	1.688	1.94	.53	.62	2.411	MK 506	1/2-13 x 2 1/4	228	3.6
		8102-32-32D							1/2-13						
2 1/2 <sup>②</sup>	2 1/2	8101-40-40D	4.00	4.50	1.75	3.500	2.000	2.44	.53	.75	2.911	MK 507	1/2-13 x 2 1/2	232	5.7
		8102-40-40D							1/2-13						
3 <sup>③</sup>	3	8101-48-48D	4.50	5.31	2.00	4.188	2.438	2.94	.66	.75	3.540	MK 508	5/8-11 x 3	237	8.3
		8102-48-48D							5/8-11						
3 1/2 <sup>④</sup>	3 1/2	8101-56-56D	5.00	6.00	1.50	4.750	2.750	3.44	.66	.75	4.045	MK 509	5/8-11 x 2 1/2	241	7.7
		8102-56-56D							5/8-11						
4 <sup>④</sup>	4	8101-64-64D	5.50	6.38	1.50	5.125	3.062	3.94	.66	.75	4.550	MK 510	5/8-11 x 2 1/2	245	8.3
		8102-64-64D							5/8-11						
5 <sup>④</sup>	5	8101-80-80D	7.00	7.25	2.00	6.000	3.625	4.94	.66	.75	5.635	MK 511	5/8-11 x 3	253	14.5
		8102-80-80D							5/8-11						

MOUNTING KITS listed contain carbon steel bolts and Buna N O-Ring. To specify stainless Grade 18-8 bolts, add an SS at the end of the kit number (MK 501SS).

Please note that using stainless steel bolts may reduce the pressure rating of the assembly.

MATERIAL:  
316L Stainless

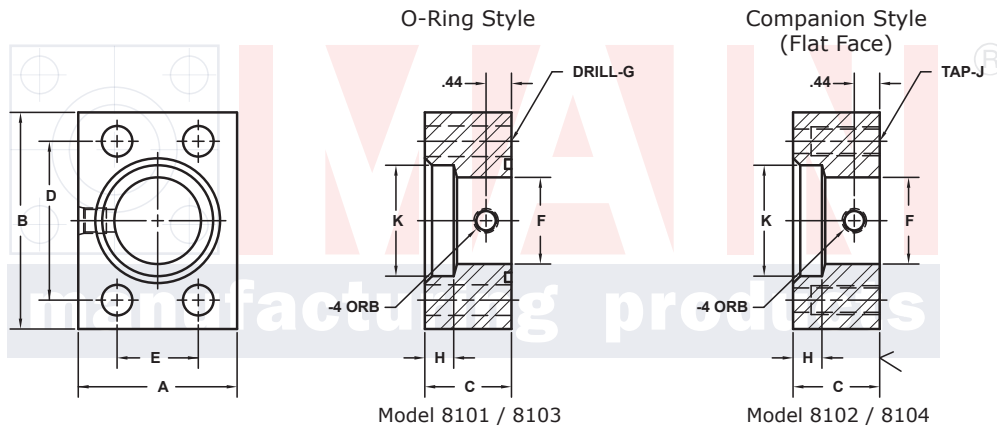

Model 8101 / 8103

Model 8102 / 8104

3181 TRI-PARK DR. GRAND BLANC, MI 48439 800-521-7918 810-953-1380 FAX 810-953-1385 INFO@MAINMFG.COM

SAE BOLT PATTERN										62 SERIES					
FLANGE SIZE	PIPE SIZE	PART NUMBER	A	B	C	D	E	F	G J	H	K	MOUNTING KIT®			WT
												PART NO.	SCREW SIZE	O-RING	
1/2	1/2	8103-08-08D	1.75	2.22	1.25	1.594	.718	.50	.34	.50	.860	MK 519	5/16-18 x 1 3/4	210	1.1
		8104-08-08D							5/16-18						
3/4	3/4	8103-12-12D	2.00	2.81	1.25	2.000	.937	.75	.41	.50	1.070	MK 520	3/8-16 x 2	214	1.5
		8104-12-12D							3/8-16						
1	1	8103-16-16D	2.25	3.19	1.25	2.250	1.093	1.00	.47	.50	1.335	MK 1504	7/16-14 x 2	219	1.9
		8104-16-16D							7/16-14						
1 1/4	1 1/4	8103-20-20D	2.75	3.75	1.25	2.625	1.250	1.25	.53	.50	1.680	MK 514	1/2-13 x 2	222	2.7
		8104-20-20D							1/2-13						
1 1/2	1 1/2	8103-24-24D	3.25	4.50	1.50	3.125	1.437	1.50	.66	.50	1.920	MK 515	5/8-11 x 2 1/2	225	4.7
		8104-24-24D							5/8-11						
2	2	8103-32-32D	4.00	5.25	1.75	3.812	1.750	1.94	.78	.62	2.411	MK 516	3/4-10 x 3	228	7.8
		8104-32-32D							3/4-10						
2 1/2	2 1/2	8103-40-40D	5.00	6.88	2.00	4.875	2.312	2.44	.94	.62	2.911	MK 517	7/8-9 x 3 1/2	232	15.2
		8104-40-40D							7/8-9						
3	3	8103-48-48D	6.00	8.50	2.50	6.000	2.812	2.94	1.19	.62	3.540	MK 718	1 1/8-7 x 4 1/2	237	27.8
		8104-48-48D							1 1/8-7						

① Order Separately

② 2500 PSI Max

③ 2000 PSI Max

④ 500 PSI Max