

SOCKET WELD PIPE ELBOW FLANGES (Pg 1/2)

SAE J518 61 SERIES / ISO6162-1 PATTERN

FLANGE SIZE	PIPE SIZE	PART NUMBER	A	B	C	D	E	F	Gmm	H	K	MOUNTING KIT®			WT
									Jmm			PART NO.	SCREW SIZE	O-RING	
1/2	1/2	1125-08-08M8	1.75	2.12	1.44	1.500	.688	.50	8.5	.75	.860	MKM 541	M8 x 50	210	1.3
		M8x1.25							-----			---			
3/4	1/2	1125-12-08M10	2.00	2.62	1.70	1.875	.875	.75	10.5	.88	.860	MKM 542	M10 x 60	214	2.1
		M10x1.5							-----			---			
3/4	3/4	1125-12-12M10	2.00	2.62	1.70	1.875	.875	.75	10.5	.88	1.070	MKM 542	M10 x 60	214	2.0
		M10x1.5							-----			---			
1	3/4	1125-16-12M10	2.25	2.82	1.94	2.062	1.031	1.00	10.5	1.00	1.070	MKM 543	M10 x 65	219	2.8
		M10x1.5							-----			---			
1	1	1125-16-16M10	2.25	2.82	1.94	2.062	1.031	1.00	10.5	1.00	1.335	MKM 543	M10 x 65	219	2.7
		M10x1.5							-----			---			
1 1/4	1	1125-20-16M10†	2.75	3.19	2.40	2.312	1.188	1.25	10.5	1.25	1.335	MKM 4532	M10 x 75	222	4.9
		M10x1.5							-----			---			
1 1/4	1 1/4	1125-20-20M10†	2.75	3.19	2.40	2.312	1.188	1.25	10.5	1.25	1.680	MKM 4532	M10 x 75	222	4.8
		M10x1.5							-----			---			
1 1/4	1 1/2	1125-20-24M10†	3.00	3.19	3.00	2.312	1.188	1.25	10.5	1.25	1.920	MKM 4597	M10 x 90	222	6.0
		M10x1.5							-----			---			
1 1/2	1 1/4	1125-24-20M10†	3.00	3.75	2.90	2.750	1.406	1.50	13.0	1.38	1.680	MKM 4533	M12 x 90	225	7.4
		M12x1.75							-----			---			
1 1/2	1 1/2	1125-24-24M12‡	3.00	3.75	2.90	2.750	1.406	1.50	13.0	1.38	1.920	MKM 4533	M12 x 90	225	7.3
		M12x1.75							-----			---			
1 1/2	2	1125-24-32M12‡	3.50	3.75	3.50	2.750	1.406	1.50	13.0	1.38	2.411	MKM 3521	M12 x 100	225	9.8
		M12x1.75							-----			---			

MATERIAL:
Low Carbon Steel

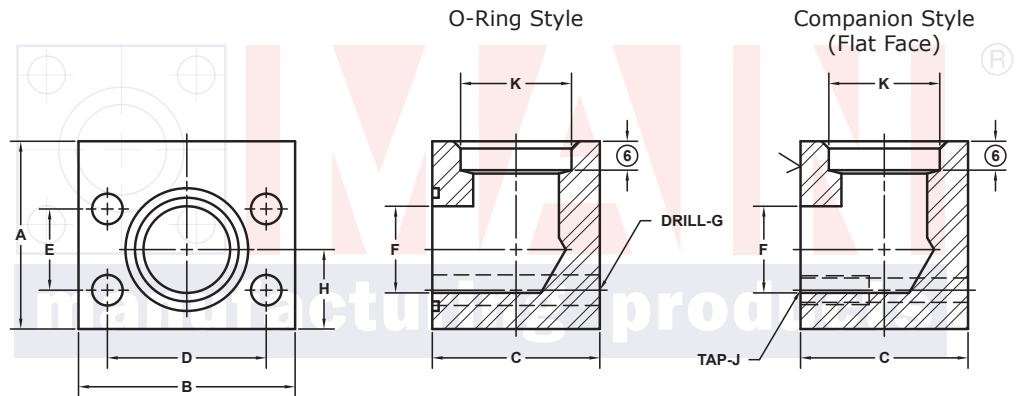
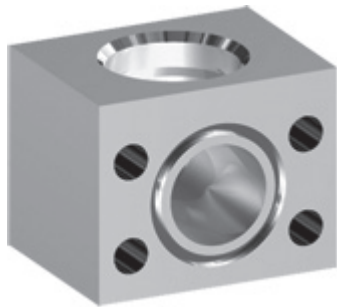

Model 1125 / 1127

Model 1126 / 1128

3181 TRI-PARK DR. GRAND BLANC, MI 48439 800-521-7918 810-953-1380 FAX 810-953-1385 INFO@MAINMFG.COM

SAE J518 62 SERIES / ISO6162-2 PATTERN

FLANGE SIZE	PIPE SIZE	PART NUMBER	A	B	C	D	E	F	Gmm	H	K	MOUNTING KIT®			WT
									Jmm			PART NO.	SCREW SIZE	O-RING	
1/2	1/2	1127-08-08M8	2.00	2.22	1.46	1.594	.718	.50	8.5	.88	.860	MKM 541	M8 x 50	210	1.6
		M8x1.25							-----			---			
3/4	1/2	1127-12-08M10	2.25	2.81	1.70	2.000	.937	.75	10.5	1.00	.860	MKM 542	M10 x 60	214	2.7
		M10x1.5							-----			---			
3/4	3/4	1127-12-12M10	2.25	2.81	1.70	2.000	.937	.75	10.5	1.00	1.070	MKM 542	M10 x 60	214	2.6
		M10x1.5							-----			---			
1	3/4	1127-16-12M12	2.50	3.19	2.21	2.250	1.093	1.00	12.5	1.12	1.070	MKM 2533	M12 x 75	219	4.2
		M12x1.75							-----			---			
1	1	1127-16-16M12	2.50	3.19	2.21	2.250	1.093	1.00	12.5	1.12	1.335	MKM 2533	M12 x 75	219	4.1
		M12x1.75							-----			---			
1 1/4	1	1127-20-16M12‡	3.00	3.75	2.44	2.625	1.250	1.25	13.0	1.38	1.335	MKM 578	M12 x 80	222	6.5
		M12x1.75							-----			---			
1 1/4	1 1/4	1127-20-20M12‡	3.00	3.75	2.44	2.625	1.250	1.25	13.0	1.38	1.680	MKM 578	M12 x 80	222	6.3
		M12x1.75							-----			---			
1 1/4	1 1/2	1127-20-24M12‡	3.00	3.75	3.00	2.625	1.250	1.25	13.0	1.38	1.920	MKM 5551	M12 x 90	222	7.6
		M12x1.75							-----			---			

① Order Separately

⑥ C'bore Depth by Pipe Size: 1/2" is .38"; 3/4" to 2" is .50"

8 NOTE: DIMENSIONS ARE IN INCHES UNLESS OTHERWISE NOTED. † Also Available for M12 Bolts ‡ Also Available for M14 Bolts

© Copyright MAIN Mfg. 2017

SOCKET WELD PIPE ELBOW FLANGES (Pg 2/2)

SAE J518 61 SERIES / ISO6162-1 PATTERN

FLANGE SIZE	PIPE SIZE	PART NUMBER	A	B	C	D	E	F	Gmm	H	K	MOUNTING KIT®			WT
									Jmm			PART NO.	SCREW SIZE	O-RING	
2	1 1/4	1125-32-20M12+	3.50	4.00	3.40	3.062	1.688	1.94	13.0	1.62	1.680	MKM 4534	M12 x 100	228	10.4
		M12x1.75							-----			---			
2	1 1/2	1125-32-24M12+	3.50	4.00	3.40	3.062	1.688	1.94	13.0	1.62	1.920	MKM 4534	M12 x 100	228	10.2
		M12x1.75							-----			---			
2	2	1125-32-32M12+	3.50	4.00	3.40	3.062	1.688	1.94	13.0	1.62	2.411	MKM 4534	M12 x 100	228	9.9
		M12x1.75							-----			---			
2 1/2 ^②	2	1125-40-32M12+	4.00	4.50	3.96	3.500	2.000	2.44	13.0	2.00	2.411	MKM 4535	M12 x 120	232	14.9
		M12x1.75							-----			---			
2 1/2 ^②	2 1/2	1125-40-40M12+	4.00	4.50	3.96	3.500	2.000	2.44	13.0	2.00	2.911	MKM 4535	M12 x 120	232	13.9
		M12x1.75							-----			---			
3 ^③	2 1/2	1125-48-40M16	5.00	5.31	4.96	4.188	2.438	2.94	17.0	2.25	2.911	MKM 548	M16 x 150	237	26.5
		M16x2							-----			---			
3 ^③	3	1125-48-48M16	5.00	5.31	4.96	4.188	2.438	2.94	17.0	2.25	3.540	MKM 548	M16 x 150	237	24.9
		M16x2							-----			---			
3 1/2 ^④	3	1125-56-48M16	5.50	6.00	5.40	4.750	2.750	3.44	17.0	2.50	3.540	MKM 549	M16 x 160	241	36.8
		M16x2							-----			---			
3 1/2 ^④	3 1/2	1125-56-56M16	5.50	6.00	5.40	4.750	2.750	3.44	17.0	2.50	4.045	MKM 549	M16 x 160	241	34.8
		M16x2							-----			---			
4 ^④	4	1125-64-64M16	6.00	6.38	5.96	5.125	3.062	3.94	17.0	2.75	4.550	MKM 550	M16 x 180	245	41.9
		M16x2							-----			---			
5 ^④	5	1125-80-80M16	7.00	7.25	6.90	6.000	3.625	4.94	17.0	3.38	5.635	MKM 1569	M16 x 200	253	60.9
		M16x2							-----			---			

MATERIAL:
Low Carbon Steel

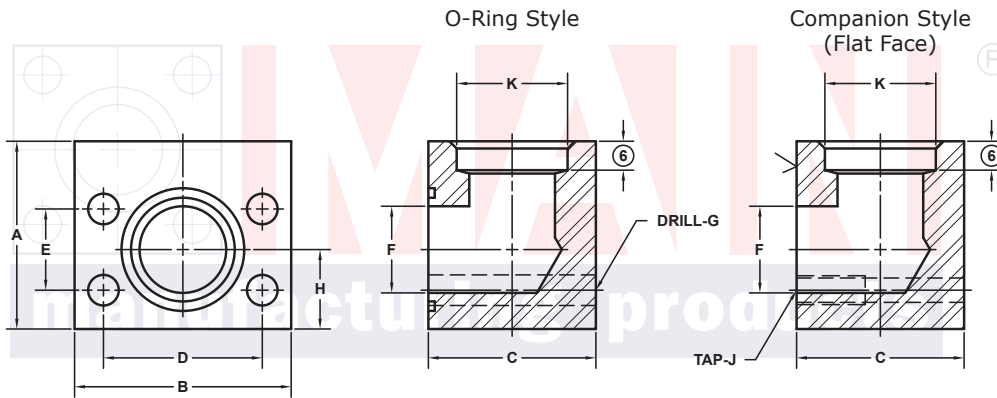

Model 1125 / 1127

Model 1126 / 1128

3181 TRI-PARK DR. GRAND BLANC, MI 48439 800-521-7918 810-953-1380 FAX 810-953-1385 INFO@MAINMFG.COM

SAE J518 62 SERIES / ISO6162-2 PATTERN

FLANGE SIZE	PIPE SIZE	PART NUMBER	A	B	C	D	E	F	Gmm	H	K	MOUNTING KIT®			WT
									Jmm			PART NO.	SCREW SIZE	O-RING	
1 1/2	1 1/4	1127-24-20M16	3.50	4.50	2.96	3.125	1.437	1.50	17.0	1.62	1.680	MKM 553	M16 x 100	225	11.0
		M16x2							-----			---			
1 1/2	1 1/2	1127-24-24M16	3.50	4.50	2.96	3.125	1.437	1.50	17.0	1.62	1.920	MKM 553	M16 x 100	225	10.7
		M16x2							-----			---			
1 1/2	2	1127-24-32M16	3.50	4.50	3.50	3.125	1.437	1.50	17.0	1.62	2.411	MKM 1598	M16 x 120	225	12.2
		M16x2							-----			---			
2	1 1/2	1127-32-24M20	4.00	5.25	3.46	3.812	1.750	1.94	21.0	2.00	1.920	MKM 554	M20 x 120	228	16.5
		M20x2.5							-----			---			
2	2	1127-32-32M20	4.00	5.25	3.46	3.812	1.750	1.94	21.0	2.00	2.411	MKM 554	M20 x 120	228	15.9
		M20x2.5							-----			---			
2 1/2	2	1127-40-32M24	5.50	6.88	4.50	4.875	2.312	2.44	25.5	2.50	2.411	MKM 2557	M24 x 150	232	40.0
		M24x3							-----			---			
2 1/2	2 1/2	1127-40-40M24	5.50	6.88	4.50	4.875	2.312	2.44	25.5	2.50	2.911	MKM 2557	M24 x 150	232	38.6
		M24x3							-----			---			
3	3	1127-48-48M30	6.00	8.50	5.00	6.000	2.812	2.94	32.0	3.00	3.540	MKM 556	M30 x 180	237	56.5
		M30x3.5							-----			---			

① Order Separately

② 2500 PSI Max ③ 2000 PSI Max ④ 500 PSI Max

⑥ C'bore Depth by Pipe Size: 1 1/4" to 2 1/2" is .50" (2 1/2" 62 Series is .62"); 3" to 5" is .62"

NOTE: DIMENSIONS ARE IN INCHES UNLESS OTHERWISE NOTED. + Also Available for M12 Bolts † Also Available for M14 Bolts

© Copyright MAIN Mfg. 2017