

SOCKET WELD TUBE ELBOW FLANGES

SAE BOLT PATTERN										61 SERIES					
FLANGE SIZE	TUBE SIZE	PART NUMBER	A	B	C	D	E	F	G J	H	K	MOUNTING KIT®			WT
												PART NO.	SCREW SIZE	O-RING	
1/2	1/2	6129-08-08D	1.75	2.12	1.44	1.500	.688	.50	.34	.75	.510	MK 541	5/16-18 x 2	210	1.3
		6130-08-08D							5/16-18						
1/2	3/4	6129-08-12D	1.75	2.12	1.44	1.500	.688	.50	.34	.75	.760	MK 541	5/16-18 x 2	210	1.2
		6130-08-12D							5/16-18						
3/4	3/4	6129-12-12D	2.00	2.62	1.70	1.875	.875	.75	.41	.88	.760	MK 542	3/8-16 x 2 1/2	214	2.0
		6130-12-12D							3/8-16						
3/4	1	6129-12-16D	2.00	2.62	1.70	1.875	.875	.75	.41	.88	1.010	MK 542	3/8-16 x 2 1/2	214	1.9
		6130-12-16D							3/8-16						
1	1	6129-16-16D	2.25	2.82	1.94	2.062	1.031	1.00	.41	1.00	1.010	MK 543	3/8-16 x 2 3/4	219	2.7
		6130-16-16D							3/8-16						
1	1 1/4	6129-16-20D	2.25	2.82	1.94	2.062	1.031	1.00	.41	1.00	1.260	MK 543	3/8-16 x 2 3/4	219	2.6
		6130-16-20D							3/8-16						
1 1/4	1 1/4	6129-20-20D	2.75	3.19	2.40	2.312	1.188	1.25	.47	1.25	1.260	MK 578	7/16-14 x 3 1/4	222	4.6
		6130-20-20D							7/16-14						
1 1/4	1 1/2	6129-20-24D	2.75	3.19	2.40	2.312	1.188	1.25	.47	1.25	1.510	MK 578	7/16-14 x 3 1/4	222	4.4
		6130-20-24D							7/16-14						
1 1/2	1 1/2	6129-24-24D	3.00	3.75	2.90	2.750	1.406	1.50	.53	1.38	1.510	MK 545	1/2-13 x 4	225	7.0
		6130-24-24D							1/2-13						
1 1/2	2	6129-24-32D	3.00	3.75	2.90	2.750	1.406	1.50	.53	1.38	2.010	MK 545	1/2-13 x 4	225	6.7
		6130-24-32D							1/2-13						
2	2	6129-32-32D	3.50	4.00	3.40	3.062	1.688	1.50	.53	1.62	2.010	MK 546	1/2-13 x 4 1/2	228	9.9
		6130-32-32D							1/2-13						

MOUNTING KITS listed contain carbon steel bolts and Buna N O-Ring. To specify stainless Grade 18-8 bolts, add an SS at the end of the kit number (MK 501SS).

Please note that using stainless steel bolts may reduce the pressure rating of the assembly.

MATERIAL:
316L Stainless

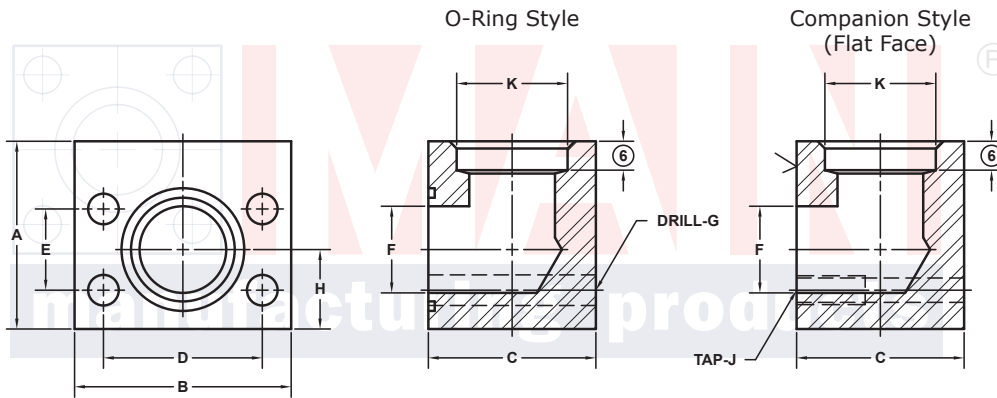

Model 6129 / 6131

Model 6130 / 6132

3181 TRI-PARK DR. GRAND BLANC, MI 48439 800-521-7918 810-953-1380 FAX 810-953-1385 INFO@MAINMFG.COM

SAE BOLT PATTERN										62 SERIES					
FLANGE SIZE	TUBE SIZE	PART NUMBER	A	B	C	D	E	F	G J	H	K	MOUNTING KIT®			WT
												PART NO.	SCREW SIZE	O-RING	
1/2	3/4	6131-08-12D	2.00	2.22	1.46	1.594	.718	.50	.34	.88	.760	MK 541	5/16-18 x 2	210	1.5
		6132-08-12D							5/16-18						
3/4	1	6131-12-16D	2.25	2.81	1.70	2.000	.937	.75	.41	1.00	1.010	MK 542	3/8-16 x 2 1/2	214	2.4
		6132-12-16D							3/8-16						
1	1	6131-16-16D	2.50	3.19	2.21	2.250	1.093	1.00	.47	1.12	1.010	MK 2533	7/16-14 x 3	219	4.0
		6132-16-16D							7/16-14						
1	1 1/4	6131-16-20D	2.50	3.19	2.21	2.250	1.093	1.00	.47	1.12	1.260	MK 2533	7/16-14 x 3	219	3.9
		6132-16-20D							7/16-14						
1 1/4	1 1/4	6131-20-20D	3.00	3.75	2.44	2.625	1.250	1.25	.53	1.38	1.260	MK 552	1/2-13 x 3 1/4	222	6.3
		6132-20-20D							1/2-13						
1 1/4	1 1/2	6131-20-24D	3.00	3.75	2.44	2.625	1.250	1.25	.53	1.38	1.510	MK 552	1/2-13 x 3 1/4	222	6.1
		6132-20-24D							1/2-13						
1 1/2	2	6131-24-32D	3.50	4.50	2.96	3.125	1.437	1.50	.66	1.62	2.010	MK 553	5/8-11 x 4	225	10.1
		6132-24-32D							5/8-11						
2	2	6131-32-32D	4.00	5.25	3.46	3.812	1.750	1.50	.78	2.00	2.010	MK 554	3/4-10 x 4 1/2	228	15.9
		6132-32-32D							3/4-10						

① Order Separately

© C'bore Depth by Pipe Size: 1/2" and 3/4" is .38"; 1" to 2" is .50"