

SOCKET WELD TUBE ELBOW FLANGES

SAE J518 61 SERIES / ISO6162-1 PATTERN

FLANGE SIZE	TUBE SIZE	PART NUMBER	A	B	C	D	E	F	Gmm		H	K	MOUNTING KIT ^①			WT
									Jmm				PART NO.	SCREW SIZE	O-RING	
1/2	1/2	1129-08-08M8	1.75	2.12	1.44	1.500	.688	.50	8.5	.75	.510	MKM 541	M8 x 50	210	1.3	
		M8x1.25														
1/2	3/4	1129-08-12M8	1.75	2.12	1.44	1.500	.688	.50	8.5	.75	.760	MKM 541	M8 x 50	210	1.2	
		M8x1.25														
3/4	3/4	1129-12-12M10	2.00	2.62	1.70	1.875	.875	.75	10.5	.88	.760	MKM 542	M10 x 60	214	2.0	
		M10x1.5														
3/4	1	1129-12-16M10	2.00	2.62	1.70	1.875	.875	.75	10.5	.88	1.010	MKM 542	M10 x 60	214	1.9	
		M10x1.5														
1	1	1129-16-16M10	2.25	2.82	1.94	2.062	1.031	1.00	10.5	1.00	1.010	MKM 543	M10 x 65	219	2.7	
		M10x1.5														
1	1 1/4	1129-16-20M10	2.25	2.82	1.94	2.062	1.031	1.00	10.5	1.00	1.260	MKM 543	M10 x 65	219	2.6	
		M10x1.5														
1 1/4	1 1/4	1129-20-20M10 [†]	2.75	3.19	2.40	2.312	1.188	1.25	10.5	1.25	1.260	MKM 4532	M10 x 75	222	4.6	
		M10x1.5														
1 1/4	1 1/2	1129-20-24M10 [†]	2.75	3.19	2.40	2.312	1.188	1.25	10.5	1.25	1.510	MKM 4532	M10 x 75	222	4.4	
		M10x1.5														
1 1/2	1 1/2	1129-24-24M12 [‡]	3.00	3.75	2.90	2.750	1.406	1.50	13.0	1.38	1.510	MKM 4533	M12 x 90	225	7.0	
		M12x1.75														
1 1/2	2	1129-24-32M12 [‡]	3.00	3.75	2.90	2.750	1.406	1.50	13.0	1.38	2.010	MKM 4533	M12 x 90	225	6.7	
		M12x1.75														
2	2	1129-32-32M12 [‡]	3.50	4.00	3.40	3.062	1.688	1.50	13.0	1.62	2.010	MKM 4534	M12 x 100	228	9.9	
		M12x1.75														

MATERIAL:
Low Carbon Steel

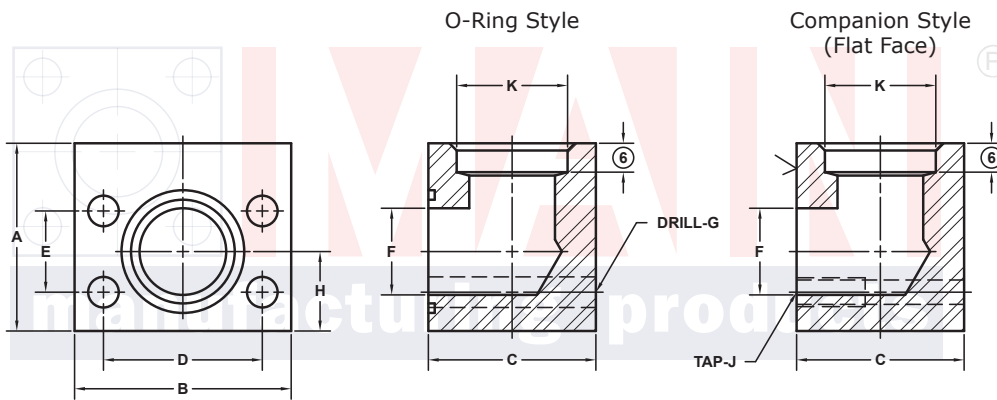

Model 1129 / 1131

Model 1130 / 1132

3181 TRI-PARK DR. GRAND BLANC, MI 48439 800-521-7918 810-953-1380 FAX 810-953-1385 INFO@MAINMFG.COM

SAE J518 62 SERIES / ISO6162-2 PATTERN

FLANGE SIZE	TUBE SIZE	PART NUMBER	A	B	C	D	E	F	Gmm		H	K	MOUNTING KIT ^①			WT
									Jmm				PART NO.	SCREW SIZE	O-RING	
1/2	3/4	1131-08-12M8	2.00	2.22	1.46	1.594	.718	.50	8.5	.88	.760	MKM 541	M8 x 50	210	1.5	
		M8x1.25														
3/4	1	1131-12-16M10	2.25	2.81	1.70	2.000	.937	.75	10.5	1.00	1.010	MKM 542	M10 x 60	214	2.4	
		M10x1.5														
1	1	1131-16-16M12	2.50	3.19	2.21	2.250	1.093	1.00	12.5	1.12	1.010	MKM 2533	M12 x 75	219	4.0	
		M12x1.75														
1	1 1/4	1131-16-20M12	2.50	3.19	2.21	2.250	1.093	1.00	12.5	1.12	1.260	MKM 2533	M12 x 75	219	3.9	
		M12x1.75														
1 1/4	1 1/4	1131-20-20M12 [‡]	3.00	3.75	2.44	2.625	1.250	1.25	13.0	1.38	1.260	MKM 578	M12 x 80	222	6.3	
		M12x1.75														
1 1/4	1 1/2	1131-20-24M12 [‡]	3.00	3.75	2.44	2.625	1.250	1.25	13.0	1.38	1.510	MKM 578	M12 x 80	222	6.1	
		M12x1.75														
1 1/2	2	1131-24-32M16	3.50	4.50	2.96	3.125	1.437	1.50	17.0	1.62	2.010	MKM 553	M16 x 100	225	10.1	
		M16x2														
2	2	1131-32-32M20	4.00	5.25	3.46	3.812	1.750	1.50	21.0	2.00	2.010	MKM 554	M20 x 120	228	15.9	
		M20x2.5														

① Order Separately

② C'bore Depth by Pipe Size: 1/2" and 3/4" is .38"; 1" to 2" is .50"

NOTE: DIMENSIONS ARE IN INCHES UNLESS OTHERWISE NOTED. † Also Available for M12 Bolts ‡ Also Available for M14 Bolts

© Copyright MAIN Mfg. 2017