

# SOCKET WELD TUBE IN-LINE FLANGES

FLANGE SIZE	TUBE SIZE	SAE BOLT PATTERN								61 SERIES					WT
		PART NUMBER	A	B	C	D	E	F	G	H	K	MOUNTING KIT®			
									J			PART NO.	SCREW SIZE	O-RING	
1/2	1/2	6113-08-08D	1.50	2.12	.75	1.500	.688	.31	.34	.38	.510	MK 501	5/16-18 x 1 1/4	210	.6
		6114-08-08D							5/16-18			-----	---		
1/2	3/4	6113-08-12D	1.50	2.12	.75	1.500	.688	.50	.34	.38	.760	MK 501	5/16-18 x 1 1/4	210	.5
		6114-08-12D							5/16-18			-----	---		
3/4	3/4	6113-12-12D	1.75	2.62	1.00	1.875	.875	.50	.41	.38	.760	MK 502	3/8-16 x 1 3/4	214	.9
		6114-12-12D							3/8-16			-----	---		
3/4	1	6113-12-16D	1.75	2.62	1.00	1.875	.875	.75	.41	.50	1.010	MK 502	3/8-16 x 1 3/4	214	.8
		6114-12-16D							3/8-16			-----	---		
1	1	6113-16-16D	2.00	2.82	1.00	2.062	1.031	.75	.41	.50	1.010	MK 503	3/8-16 x 1 3/4	219	1.3
		6114-16-16D							3/8-16			-----	---		
1	1 1/4	6113-16-20D	2.00	2.82	1.00	2.062	1.031	1.00	.41	.50	1.260	MK 503	3/8-16 x 1 3/4	219	1.2
		6114-16-20D							3/8-16			-----	---		
1 1/4	1 1/4	6113-20-20D	2.50	3.19	1.00	2.312	1.188	1.00	.47	.50	1.260	MK 504	7/16-14 x 1 3/4	222	1.7
		6114-20-20D							7/16-14			-----	---		
1 1/4	1 1/2	6113-20-24D	2.50	3.19	1.00	2.312	1.188	1.25	.47	.50	1.510	MK 504	7/16-14 x 1 3/4	222	1.6
		6114-20-24D							7/16-14			-----	---		
1 1/2	1 1/2	6113-24-24D	2.75	3.75	1.25	2.750	1.406	1.25	.53	.50	1.510	MK 505	1/2-13 x 2	225	2.7
		6114-24-24D							1/2-13			-----	---		
1 1/2	2	6113-24-32D	2.75	3.75	1.25	2.750	1.406	1.50	.53	.50	2.010	MK 505	1/2-13 x 2	225	2.5
		6114-24-32D							1/2-13			-----	---		
2	2	6113-32-32D	3.25	4.00	1.50	3.062	1.688	1.50	.53	.50	2.010	MK 506	1/2-13 x 2 1/4	228	4.1
		6114-32-32D							1/2-13			-----	---		

MATERIAL:  
316L Stainless

MOUNTING KITS listed contain carbon steel bolts and Buna N O-Ring. To specify stainless Grade 18-8 bolts, add an SS at the end of the kit number (MK 501SS).

Please note that using stainless steel bolts may reduce the pressure rating of the assembly.

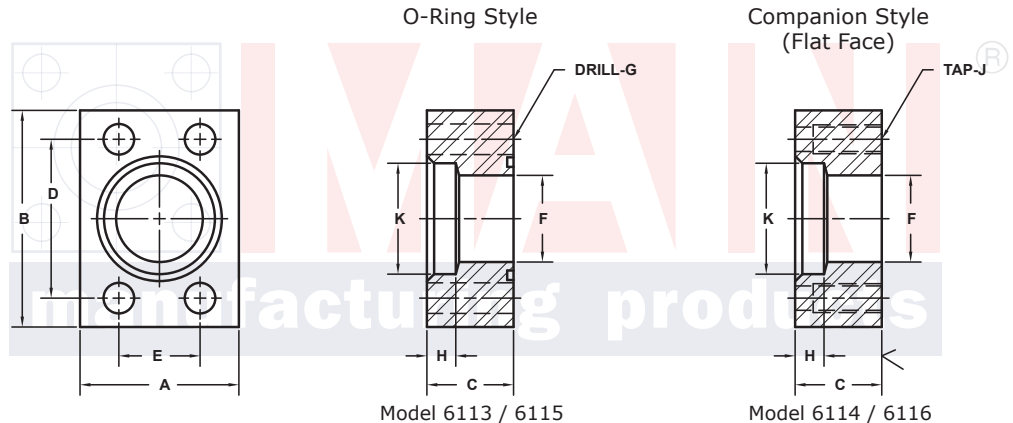
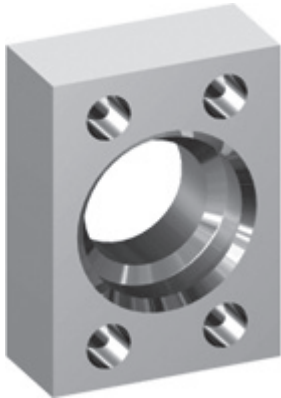

3181 TRI-PARK DR. GRAND BLANC, MI 48439 800-521-7918 810-953-1380 FAX 810-953-1385 INFO@MAINMFG.COM

FLANGE SIZE	TUBE SIZE	SAE BOLT PATTERN								62 SERIES					WT
		PART NUMBER	A	B	C	D	E	F	G	H	K	MOUNTING KIT®			
									J			PART NO.	SCREW SIZE	O-RING	
1/2	3/4	6115-08-12D	1.75	2.22	1.00	1.594	.718	.50	.34	.50	.760	MK 512	5/16-18 x 1 1/2	210	.8
		6116-08-12D							5/16-18			-----	---		
3/4	1	6115-12-16D	2.00	2.81	1.00	2.000	.937	.75	.41	.50	1.010	MK 502	3/8-16 x 1 3/4	214	1.2
		6116-12-16D							3/8-16			-----	---		
1	1	6115-16-16D	2.25	3.19	1.00	2.250	1.093	.75	.47	.50	1.010	MK 513	7/16-14 x 1 3/4	219	1.6
		6116-16-16D							7/16-14			-----	---		
1	1 1/4	6115-16-20D	2.25	3.19	1.00	2.250	1.093	1.00	.47	.50	1.260	MK 513	7/16-14 x 1 3/4	219	1.5
		6116-16-20D							7/16-14			-----	---		
1 1/4	1 1/4	6115-20-20D	2.75	3.75	1.25	2.625	1.250	1.00	.53	.50	1.260	MK 514	1/2-13 x 2	222	2.9
		6116-20-20D							1/2-13			-----	---		
1 1/4	1 1/2	6115-20-24D	2.75	3.75	1.25	2.625	1.250	1.25	.53	.50	1.510	MK 514	1/2-13 x 2	222	2.8
		6116-20-24D							1/2-13			-----	---		
1 1/2	2	6115-24-32D	3.25	4.50	1.50	3.125	1.437	1.50	.66	.50	2.010	MK 515	5/8-11 x 2 1/2	225	4.7
		6116-24-32D							5/8-11			-----	---		
2	2	6115-32-32D	4.00	5.25	1.75	3.812	1.750	1.50	.78	.50	2.010	MK 516	3/4-10 x 3	228	8.3
		6116-32-32D							3/4-10			-----	---		

① Order Separately