

SPACERS AND GAUGE PORT ADAPTERS

1/4" GAUGE PORTS

| SAE BOLT PATTERN | | | 61 SERIES | | | | | | | | | |
|--------------------|-----------|-------------|-----------|------|------|-------|-------|------|-----|-------|---------------------|-----|
| FLANGE SIZE | PIPE SIZE | PART NUMBER | A | B | C | D | E | F | G | L | O-RING ^① | WT |
| 1/2 | NA | 6303-08-08D | 1.50 | 2.12 | 1.00 | 1.500 | .688 | .50 | .34 | 1.000 | 210 | .7 |
| | | 7303-08-08D | | | | | | | | | | |
| | | 8303-08-08D | | | | | | | | | | |
| 3/4 | NA | 6303-12-12D | 1.75 | 2.62 | 1.00 | 1.875 | .875 | .75 | .41 | 1.250 | 214 | 1.0 |
| | | 7303-12-12D | | | | | | | | | | |
| | | 8303-12-12D | | | | | | | | | | |
| 1 | NA | 6303-16-16D | 2.00 | 2.82 | 1.00 | 2.062 | 1.031 | 1.00 | .41 | 1.562 | 219 | 1.1 |
| | | 7303-16-16D | | | | | | | | | | |
| | | 8303-16-16D | | | | | | | | | | |
| 1 1/4 | NA | 6303-20-20D | 2.50 | 3.19 | 1.00 | 2.312 | 1.188 | 1.25 | .47 | 1.750 | 222 | 1.6 |
| | | 7303-20-20D | | | | | | | | | | |
| | | 8303-20-20D | | | | | | | | | | |
| 1 1/2 | NA | 6303-24-24D | 2.75 | 3.75 | 1.00 | 2.750 | 1.406 | 1.50 | .53 | 2.125 | 225 | 2.0 |
| | | 7303-24-24D | | | | | | | | | | |
| | | 8303-24-24D | | | | | | | | | | |
| 2 | NA | 6303-32-32D | 3.25 | 4.00 | 1.00 | 3.062 | 1.688 | 1.94 | .53 | 2.500 | 228 | 2.4 |
| | | 7303-32-32D | | | | | | | | | | |
| | | 8303-32-32D | | | | | | | | | | |
| 2 1/2 ^② | NA | 6303-40-40D | 4.00 | 4.50 | 1.00 | 3.500 | 2.000 | 2.44 | .53 | 3.000 | 232 | 3.3 |
| | | 7303-40-40D | | | | | | | | | | |
| | | 8303-40-40D | | | | | | | | | | |
| 3 ^③ | NA | 6303-48-48D | 4.50 | 5.31 | 1.00 | 4.188 | 2.438 | 2.94 | .66 | 3.625 | 237 | 4.1 |
| | | 7303-48-48D | | | | | | | | | | |
| | | 8303-48-48D | | | | | | | | | | |

MATERIAL:
316L Stainless

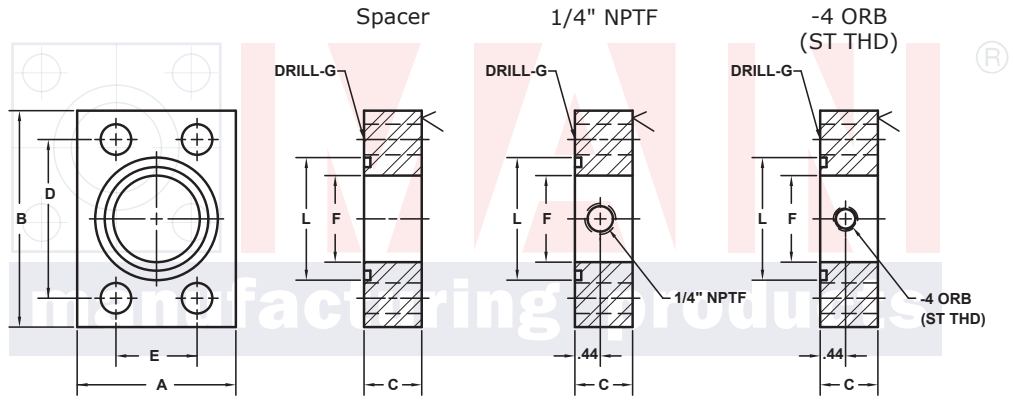

3181 TRI-PARK DR. GRAND BLANC, MI 48439 800-521-7918 810-953-1380 FAX 810-953-1385 INFO@MAINMFG.COM

| SAE BOLT PATTERN | | | 62 SERIES | | | | | | | | | |
|------------------|-----------|-------------|-----------|------|------|-------|-------|------|-----|-------|---------------------|-----|
| FLANGE SIZE | PIPE SIZE | PART NUMBER | A | B | C | D | E | F | G | L | O-RING ^① | WT |
| 1/2 | NA | 6305-08-08D | 1.75 | 2.22 | 1.00 | 1.594 | .718 | .50 | .34 | 1.000 | 210 | .8 |
| | | 7305-08-08D | | | | | | | | | | |
| | | 8305-08-08D | | | | | | | | | | |
| 3/4 | NA | 6305-12-12D | 2.00 | 2.81 | 1.00 | 2.000 | .937 | .75 | .41 | 1.250 | 214 | 1.2 |
| | | 7305-12-12D | | | | | | | | | | |
| | | 8305-12-12D | | | | | | | | | | |
| 1 | NA | 6305-16-16D | 2.25 | 3.19 | 1.00 | 2.250 | 1.093 | 1.00 | .47 | 1.562 | 219 | 1.5 |
| | | 7305-16-16D | | | | | | | | | | |
| | | 8305-16-16D | | | | | | | | | | |
| 1 1/4 | NA | 6305-20-20D | 2.75 | 3.75 | 1.00 | 2.625 | 1.250 | 1.25 | .53 | 1.750 | 222 | 2.2 |
| | | 7305-20-20D | | | | | | | | | | |
| | | 8305-20-20D | | | | | | | | | | |
| 1 1/2 | NA | 6305-24-24D | 3.25 | 4.50 | 1.00 | 3.125 | 1.437 | 1.50 | .66 | 2.125 | 225 | 3.1 |
| | | 7305-24-24D | | | | | | | | | | |
| | | 8305-24-24D | | | | | | | | | | |
| 2 | NA | 6305-32-32D | 4.00 | 5.25 | 1.00 | 3.812 | 1.750 | 1.94 | .78 | 2.500 | 228 | 4.3 |
| | | 7305-32-32D | | | | | | | | | | |
| | | 8305-32-32D | | | | | | | | | | |

① Includes Buna-N O-Ring ② 2500 PSI Max ③ 2000 PSI Max