

SPLIT FLANGES

SAE J518 61 SERIES / ISO 6162-1 PATTERN (J518 61 SERIES METRIC)

FLANGE SIZE		PART NUMBER	A	B	C	D	E	F	G	H	J	K	MOUNTING KIT ①		
													PART NO.	SCREW SIZE	O-RING
1/2	13	6319-08-08 6319-08-08M8	1.81	2.12	.75	1.500	.688	.955	.34 [8.5]	.245	.50	1.219	MK 701 MKM 764	5/16-18 x 1 1/4 M8 x 25	210
3/4	19	6319-12-12 6319-12-12M10	2.05	2.56	.88	1.875	.875	1.265	.41 [11.0]	.245	.56	1.531	MK 1743 MKM 1743	3/8-16 x 1 1/4 M10 x 30	214
1	25	6319-16-16 6319-16-16M10	2.31	2.75	.94	2.062	1.031	1.515	.41 [11.0]	.295	.62	1.781	MK 2735 MKM 2735	3/8-16 x 1 1/4 M10 x 30	219
1 1/4	32	6319-20-20 6319-20-20M10 6319-20-20M12*	2.88	3.12	.88	2.312	1.188	1.720	.47 [11.0] [13.5]	.295	.56	2.031	MK 1727 MKM 2767 MKM 767	7/16-14 x 1 1/2 M10 x 30 M12 x 35	222
1 1/2	38	6319-24-24 6319-24-24M12 6319-24-24M14*	3.25	3.69	1.00	2.750	1.406	2.000	.53 [13.5] [15.0]	.295	.62	2.406	MK 2736 MKM 3735 MKM 2736	1/2-13 x 1 1/2 M12 x 35 M14 x 40	225
2	51	6319-32-32 6319-32-32M12 6319-32-32M14*	3.81	4.00	1.03	3.062	1.688	2.470	.53 [13.5] [15.0]	.355	.62	2.844	MK 2737 MKM 3737 MKM 2737	1/2-13 x 1 1/2 M12 x 35 M14 x 40	228
2 1/2 ②	64	6319-40-40 6319-40-40M12 6319-40-40M14*	4.28	4.50	1.50	3.500	2.000	2.950	.53 [13.5] [15.0]	.355	.75	3.344	MK 1728 MKM 3738 MKM 1728	1/2-13 x 1 3/4 M12 x 40 M14 x 45	232
3 ③	76	6319-48-48 6319-48-48M16	5.16	5.31	1.62	4.188	2.438	3.580	.66 [16.7]	.355	.88	4.031	MK 2738 MKM 1711	5/8-11 x 1 3/4 M16 x 50	237
3 1/2 ④	89	6319-56-56 6319-56-56M16	5.50	6.00	1.12	4.750	2.750	4.030	.66 [16.7]	.422	.88	4.531	MK 1771 MKM 1771	5/8-11 x 2 M16 x 50	241
4 ④	102	6319-64-64 6319-64-64M16	6.00	6.38	1.38	5.125	3.062	4.530	.66 [16.7]	.422	1.00	5.031	MK 1772 MKM 1772	5/8-11 x 2 M16 x 50	245

MOUNTING KITS listed contain carbon steel bolts and Buna N O-Ring. To specify stainless Grade 18-8 bolts, add an SS at the end of the kit number (MK 501SS).

Please note that using stainless steel bolts may reduce the pressure rating of the assembly.

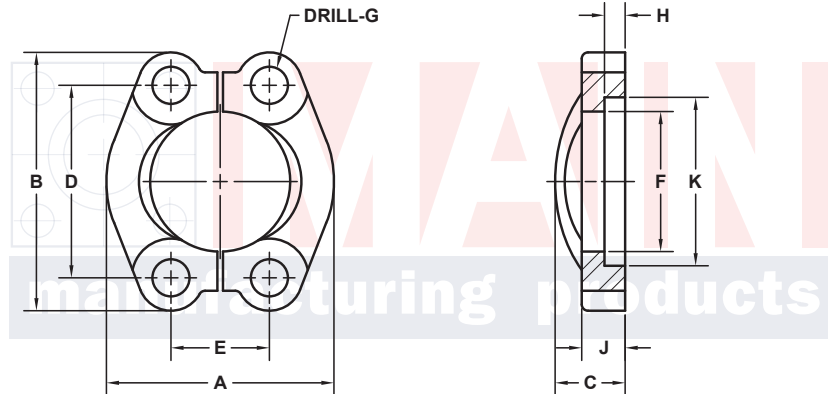
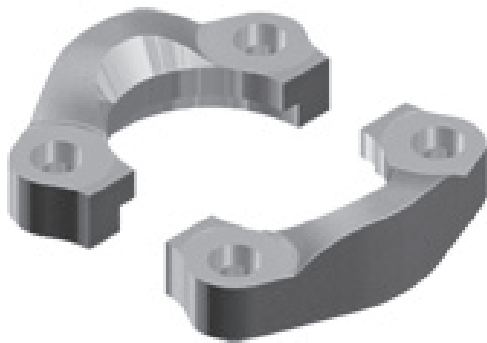

3181 TRI-PARK DR. GRAND BLANC, MI 48439 800-521-7918 810-953-1380 FAX 810-953-1385 INFO@MAINMFG.COM

SAE J518 62 SERIES / ISO 6162-2 PATTERN (J518 62 SERIES METRIC)

FLANGE SIZE		PART NUMBER	A	B	C	D	E	F	G	H	J	K	MOUNTING KIT ①		
													PART NO.	SCREW SIZE	O-RING
1/2	13	6320-08-08 6320-08-08M8	1.88	2.22	.88	1.594	.718	.970	.34 [8.5]	.285	.62	1.281	MK 701 MKM 701	5/16-18 x 1 1/4 M8 x 30	210
3/4	19	6320-12-12 6320-12-12M10	2.38	2.81	1.12	2.000	.937	1.280	.41 [11.0]	.325	.75	1.656	MK 1725 MKM 1725	3/8-16 x 1 1/2 M10 x 35	214
1	25	6320-16-16 6320-16-16M12	2.75	3.19	1.31	2.250	1.093	1.530	.47 [13.5]	.355	.94	1.906	MK 713 MKM 713	7/16-14 x 1 3/4 M12 x 45	219
1 1/4	32	6320-20-20 6320-20-20M12 6320-20-20M14*	3.06	3.75	1.50	2.625	1.250	1.750	.53 [13.5] [15.0]	.385	1.06	2.156	MK 2740 MKM 704 MKM 2740	1/2-13 x 2 M12 x 45 M14 x 50	222
1 1/2	38	6320-24-24 6320-24-24M16	3.75	4.44	1.69	3.125	1.437	2.030	.66 [16.7]	.475	1.19	2.531	MK 2741 MKM 2741	5/8-11 x 2 1/4 M16 x 55	225
2	51	6320-32-32 6320-32-32M20	4.50	5.25	2.06	3.812	1.750	2.660	.78 [22.0]	.475	1.44	3.156	MK 2743 MKM 2743	3/4-10 x 2 3/4 M20 x 70	228

① Order Separately ② 2500 PSI Max [12.5MPa Max] ③ 2000 PSI Max [10 MPa Max] ④ 500 PSI Max [2.5 MPa Max]

⑥ Includes Both Halves

* Non Standard Screw For This Flange Size

NOTE: ALL Dimensions are in Inches. Metric Equivalents are in [].

© Copyright MAIN Mfg. 2017