

FLANGE ADAPTERS

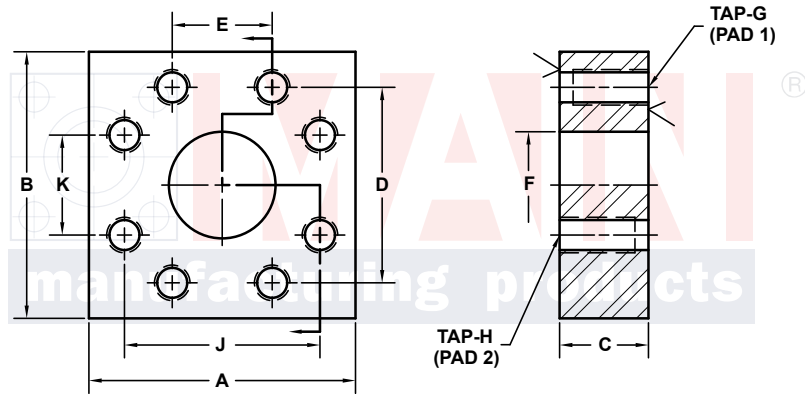
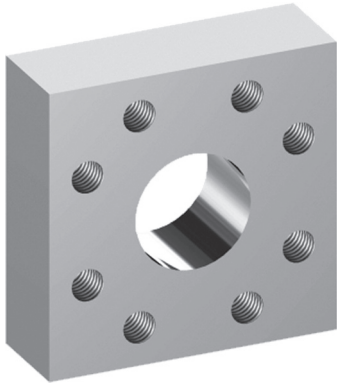

3181 TRI-PARK DR. GRAND BLANC, MI 48439 800-521-7918 810-953-1380 FAX 810-953-1385 INFO@MAINMFG.COM

SAE BOLT PATTERN			62 SERIES TO 62 SERIES										
PAD 1 C62	PAD 2 C62	PART NUMBER	A	B	C	D	E	F	G	H	J	K	
1/2	1/2	6342-08-08D	2.25	2.25	1.00	1.594	.718	.50	5/16-18	5/16-18	1.594	.718	
3/4	3/4	6342-12-12D	3.00	3.00	1.00	2.000	.937	.75	3/8-16	3/8-16	2.000	.937	
3/4	1/2	6342-12-08D	2.25	2.81	1.50	2.000	.937	.50	3/8-16	5/16-18	1.594	.718	
1	1	6342-16-16D	3.25	3.25	1.25	2.250	1.093	1.00	7/16-14	7/16-14	2.250	1.093	
1	3/4	6342-16-12D	3.00	3.19	1.75	2.250	1.093	.75	7/16-14	3/8-16	2.000	.937	
1	1/2	6342-16-08D	2.25	3.19	1.50	2.250	1.093	.50	7/16-14	5/16-18	1.594	.718	
1 1/4	1 1/4	6342-20-20D	3.75	3.75	1.25	2.625	1.250	1.25	1/2-13	1/2-13	2.625	1.250	
1 1/4	1	6342-20-16D	3.25	3.75	1.75	2.625	1.250	1.00	1/2-13	7/16-14	2.250	1.093	
1 1/4	3/4	6342-20-12D	2.81	3.75	1.75	2.625	1.250	.75	1/2-13	3/8-16	2.000	.937	
1 1/4	1/2	6342-20-08D	2.75	3.75	1.50	2.625	1.250	.50	1/2-13	5/16-18	1.594	.718	
1 1/2	1 1/2	6342-24-24D	4.50	4.50	1.75	3.125	1.437	1.50	5/8-11	5/8-11	3.125	1.437	
1 1/2	1 1/4	6342-24-20D	3.75	4.50	2.00	3.125	1.437	1.25	5/8-11	1/2-13	2.625	1.250	
1 1/2	1	6342-24-16D	3.25	4.50	2.00	3.125	1.437	1.00	5/8-11	7/16-14	2.250	1.093	
1 1/2	3/4	6342-24-12D	3.25	4.50	1.75	3.125	1.437	.75	5/8-11	3/8-16	2.000	.937	
1 1/2	1/2	6342-24-08D	3.25	4.50	1.50	3.125	1.437	.50	5/8-11	5/16-18	1.594	.718	

FLANGE ADAPTERS

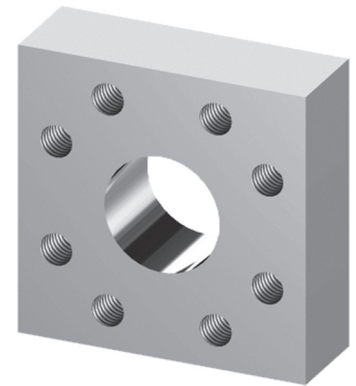
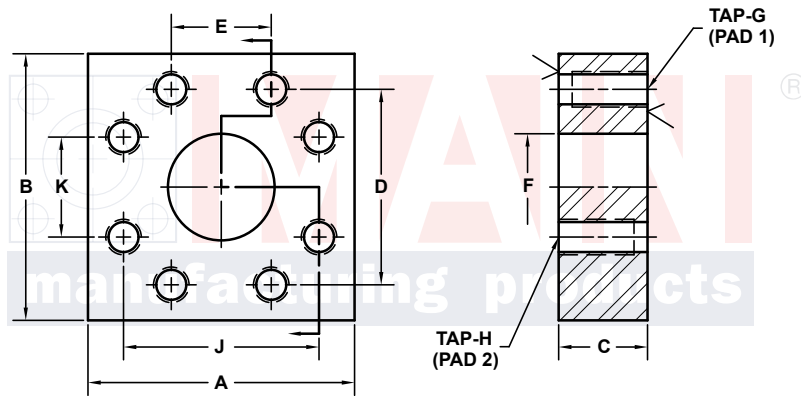

3181 TRI-PARK DR. GRAND BLANC, MI 48439 800-521-7918 810-953-1380 FAX 810-953-1385 INFO@MAINMFG.COM

SAE BOLT PATTERN			62 SERIES TO 62 SERIES										
PAD 1 C62	PAD 2 C62	PART NUMBER	A	B	C	D	E	F	G	H	J	K	
2	2	6342-32-32D	5.25	5.25	1.75	3.812	1.750	1.94	3/4-10	3/4-10	3.812	1.750	
2	1½	6342-32-24D	4.50	5.25	2.25	3.812	1.750	1.50	3/4-10	5/8-11	3.125	1.437	
2	1¼	6342-32-20D	4.00	5.25	2.00	3.812	1.750	1.25	3/4-10	1/2-13	2.625	1.250	
2	1	6342-32-16D	4.00	5.25	1.75	3.812	1.750	1.00	3/4-10	7/16-14	2.250	1.093	
2	¾	6342-32-12D	4.00	5.25	1.75	3.812	1.750	.75	3/4-10	3/8-16	2.000	.937	
2	½	6342-32-08D	4.00	5.25	1.75	3.812	1.750	.50	3/4-10	5/16-18	1.594	.718	
2½ ^①	2½ ^①	6342-40-40D	6.88	7.00	2.00	4.875	2.312	2.44	7/8-9	7/8-9	4.875	2.312	
2½ ^①	2	6342-40-32D	5.25	7.00	2.50	4.875	2.312	1.94	7/8-9	3/4-10	3.812	1.750	
2½ ^①	1½	6342-40-24D	5.00	7.00	2.50	4.875	2.312	1.50	7/8-9	5/8-11	3.125	1.437	
2½ ^①	1¼	6342-40-20D	5.00	6.88	2.00	4.875	2.312	1.25	7/8-9	1/2-13	2.625	1.250	
2½ ^①	1	6342-40-16D	5.00	6.88	2.00	4.875	2.312	1.00	7/8-9	7/16-14	2.250	1.093	
2½ ^①	¾	6342-40-12D	5.00	6.88	2.00	4.875	2.312	.75	7/8-9	3/8-16	2.000	.937	
2½ ^①	½	6342-40-08D	5.00	6.88	2.00	4.875	2.312	.50	7/8-9	5/16-18	1.594	.718	
3 ^①	3 ^①	6342-48-48D	8.50	8.50	2.50	6.000	2.812	2.94	1 1/8-7	1 1/8-7	6.000	2.812	
3 ^①	2½ ^①	6342-48-40D	7.00	8.50	2.50	6.000	2.812	2.44	1 1/8-7	7/8-9	4.875	2.312	
3 ^①	2	6342-48-32D	6.00	8.50	2.50	6.000	2.812	1.94	1 1/8-7	3/4-10	3.812	1.750	
3 ^①	1½	6342-48-24D	6.00	8.50	2.50	6.000	2.812	1.50	1 1/8-7	5/8-11	3.125	1.437	
3 ^①	1¼	6342-48-20D	6.00	8.50	2.50	6.000	2.812	1.25	1 1/8-7	1/2-13	2.625	1.250	
3 ^①	1	6342-48-16D	6.00	8.50	2.50	6.000	2.812	1.00	1 1/8-7	7/16-14	2.250	1.093	

① Not included in SAE J518 specifications