

# FLANGE ADAPTERS

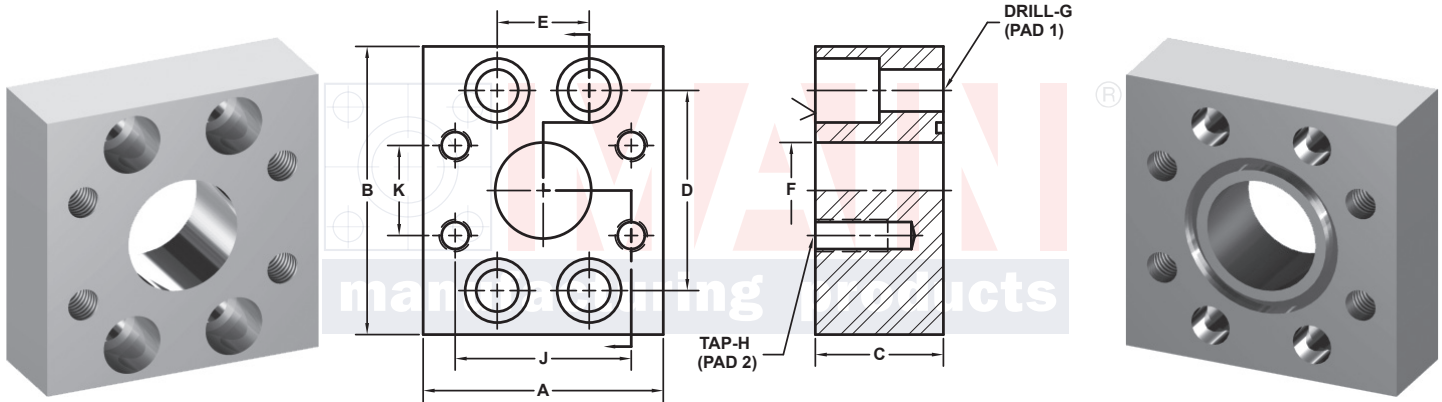

3181 TRI-PARK DR. GRAND BLANC, MI 48439 800-521-7918 810-953-1380 FAX 810-953-1385 INFO@MAINMFG.COM

SAE BOLT PATTERN													62 SERIES TO 62 SERIES			
PAD 1 C62	PAD 2 C62	PART NUMBER	A	B	C	D	E	F	G	H	J	K	MOUNTING KIT <sup>①</sup>			
													PART NO.	BOLT SIZE	O-RING	
<b>1/2</b>	<b>1/2</b>	6341-08-08D	2.25	2.25	1.00	1.594	.718	.50	.34	5/16-18	1.594	.718	MK 564	5/16-18 x 1	210	
<b>3/4</b>	<b>3/4</b>	6341-12-12D	3.00	3.00	1.00	2.000	.937	.75	.41	3/8-16	2.000	.937	MK 565	3/8-16 x 1	214	
<b>3/4</b>	<b>1/2</b>	6341-12-08D	2.25	2.81	1.50	2.000	.937	.50	.41	5/16-18	1.594	.718	MK 1525	3/8-16 x 1 1/2	214	
<b>1</b>	<b>1</b>	6341-16-16D	3.25	3.25	1.25	2.250	1.093	1.00	.47	7/16-14	2.250	1.093	MK 569	7/16-14 x 1 1/4	219	
<b>1</b>	<b>3/4</b>	6341-16-12D	3.00	3.19	1.75	2.250	1.093	.75	.47	3/8-16	2.000	.937	MK 513	7/16-14 x 1 3/4	219	
<b>3/4</b>	<b>1/2</b>	6341-16-08D	2.25	3.19	1.50	2.250	1.093	.50	.47	5/16-18	1.594	.718	MK 1529	7/16-14 x 1 1/2	219	
<b>1 1/4</b>	<b>1 1/4</b>	6341-20-20D	3.75	3.75	1.25	2.625	1.250	1.25	.53	1/2-13	2.625	1.250	MK 570	1/2-13 x 1 1/4	222	
<b>1 1/4</b>	<b>1</b>	6341-20-16D	3.25	3.75	1.75	2.625	1.250	1.00	.53	7/16-14	2.250	1.093	MK 529	1/2-13 x 1 3/4	222	
<b>1 1/4</b>	<b>3/4</b>	6341-20-12D	2.81	3.75	1.75	2.625	1.250	.75	.53	3/8-16	2.000	.937	MK 529	1/2-13 x 1 3/4	222	
<b>1 1/4</b>	<b>1/2</b>	6341-20-08D	2.75	3.75	1.50	2.625	1.250	.50	.53	5/16-18	1.594	.718	MK 1523	1/2-13 x 1 1/2	222	
<b>1 1/2</b>	<b>1 1/2</b>	6341-24-24D	4.50	4.50	1.75	3.125	1.437	1.50	.66	5/8-11	3.125	1.437	MK 1544	5/8-11 x 1 3/4	225	
<b>1 1/2</b>	<b>1 1/4</b>	6341-24-20D	3.75	4.50	2.00	3.125	1.437	1.25	.66	1/2-13	2.625	1.250	MK 562	5/8-11 x 2	225	
<b>1 1/2</b>	<b>1</b>	6341-24-16D	3.25	4.50	2.00	3.125	1.437	1.00	.66	7/16-14	2.250	1.093	MK 562	5/8-11 x 2	225	
<b>1 1/2</b>	<b>3/4</b>	6341-24-12D	3.25	4.50	1.75	3.125	1.437	.75	.66	3/8-16	2.000	.937	MK 1544	5/8-11 x 1 3/4	225	
<b>1 1/2</b>	<b>1/2</b>	6341-24-08D	3.25	4.50	1.50	3.125	1.437	.50	.66	5/16-18	1.594	.718	MK 571	5/8-11 x 1 1/2	225	

① Order Separately

# FLANGE ADAPTERS

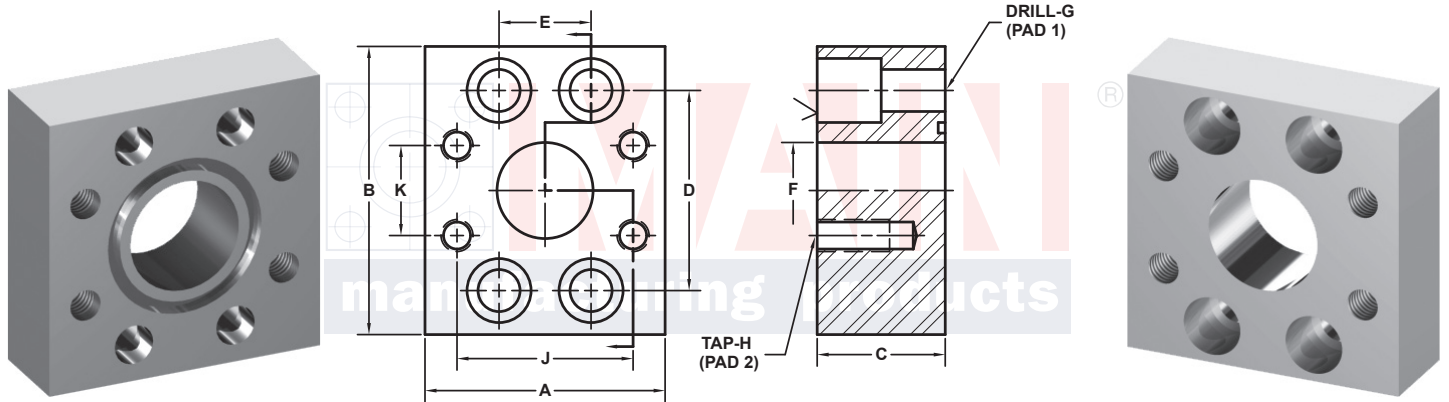

3181 TRI-PARK DR. GRAND BLANC, MI 48439 800-521-7918 810-953-1380 FAX 810-953-1385 INFO@MAINMFG.COM

## SAE BOLT PATTERN

## 62 SERIES TO 62 SERIES

PAD 1 C62	PAD 2 C62	PART NUMBER	A	B	C	D	E	F	G	H	J	K	MOUNTING KIT <sup>①</sup>		
													PART NO.	BOLT SIZE	O-RING
2	2	6341-32-32D	5.25	5.25	1.75	3.812	1.750	1.94	.78	3/4-10	3.812	1.750	MK 563	3/4-10 x 2	228
2	1½	6341-32-24D	4.50	5.25	2.25	3.812	1.750	1.50	.78	5/8-11	3.125	1.437	MK 1548	3/4-10 x 2 1/2	228
2	1¼	6341-32-20D	4.00	5.25	2.00	3.812	1.750	1.25	.78	1/2-13	2.625	1.250	MK 1574	3/4-10 x 2 1/4	228
2	1	6341-32-16D	4.00	5.25	1.75	3.812	1.750	1.00	.78	7/16-14	2.250	1.093	MK 563	3/4-10 x 2	228
2	¾	6341-32-12D	4.00	5.25	1.75	3.812	1.750	.75	.78	3/8-16	2.000	.937	MK 563	3/4-10 x 2	228
2	½	6341-32-08D	4.00	5.25	1.75	3.812	1.750	.50	.78	5/16-18	1.594	.718	MK 563	3/4-10 x 2	228
2½ <sup>②</sup>	2½ <sup>②</sup>	6341-40-40D	6.88	7.00	2.00	4.875	2.312	2.44	.94	7/8-9	4.875	2.312	MK 1513	7/8-9 x 2 1/4	232
2½ <sup>②</sup>	2	6341-40-32D	5.25	7.00	2.50	4.875	2.312	1.94	.94	3/4-10	3.812	1.750	MK 1575	7/8-9 x 2 3/4	232
2½ <sup>②</sup>	1½	6341-40-24D	5.00	7.00	2.50	4.875	2.312	1.50	.94	5/8-11	3.125	1.437	MK 1575	7/8-9 x 2 3/4	232
2½ <sup>②</sup>	1¼	6341-40-20D	5.00	6.88	2.00	4.875	2.312	1.25	.94	1/2-13	2.625	1.250	MK 1513	7/8-9 x 2 1/4	232
2½ <sup>②</sup>	1	6341-40-16D	5.00	6.88	2.00	4.875	2.312	1.00	.94	7/16-14	2.250	1.093	MK 1513	7/8-9 x 2 1/4	232
2½ <sup>②</sup>	¾	6341-40-12D	5.00	6.88	2.00	4.875	2.312	.75	.94	3/8-16	2.000	.937	MK 1513	7/8-9 x 2 1/4	232
2½ <sup>②</sup>	½	6341-40-08D	5.00	6.88	2.00	4.875	2.312	.50	.94	5/16-18	1.594	.718	MK 1513	7/8-9 x 2 1/4	232
3 <sup>②</sup>	3 <sup>②</sup>	6341-48-48D	8.50	8.50	2.50	6.000	2.812	2.94	1.19	1 1/8-7	6.000	2.812	MK 1514	1 1/8-7 x 2 1/2	237
3 <sup>②</sup>	2½ <sup>②</sup>	6341-48-40D	7.00	8.50	2.50	6.000	2.812	2.44	1.19	7/8-9	4.875	2.312	MK 1514	1 1/8-7 x 2 1/2	237
3 <sup>②</sup>	2	6341-48-32D	6.00	8.50	2.50	6.000	2.812	1.94	1.19	3/4-10	3.812	1.750	MK 1514	1 1/8-7 x 2 1/2	237
3 <sup>②</sup>	1½	6341-48-24D	6.00	8.50	2.50	6.000	2.812	1.50	1.19	5/8-11	3.125	1.437	MK 1514	1 1/8-7 x 2 1/2	237
3 <sup>②</sup>	1¼	6341-48-20D	6.00	8.50	2.50	6.000	2.812	1.25	1.19	1/2-13	2.625	1.250	MK 1514	1 1/8-7 x 2 1/2	237
3 <sup>②</sup>	1	6341-48-16D	6.00	8.50	2.50	6.000	2.812	1.00	1.19	7/16-14	2.250	1.093	MK 1514	1 1/8-7 x 2 1/2	237

① Order Separately ② Not included in SAE J518 specifications

# FLANGE ADAPTERS

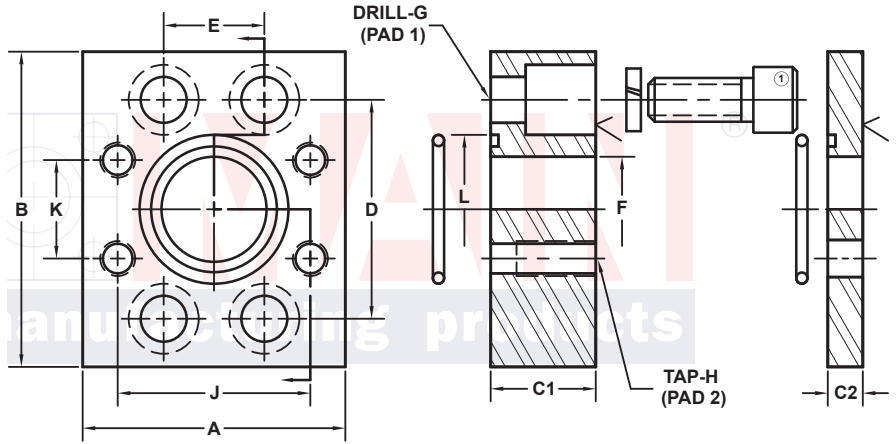

3181 TRI-PARK DR. GRAND BLANC, MI 48439 800-521-7918 810-953-1380 FAX 810-953-1385 INFO@MAINMFG.COM

SAE BOLT PATTERN															62 SERIES TO 62 SERIES		
PAD 1 C62	PAD 2 C62	PART NUMBER	A	B	C1	C2	D	E	F	G	H	J	K	L	MOUNTING KIT <sup>①</sup>		
															BOLT SIZE	O-RINGS	
<b>1/2</b>	<b>3/4</b>	6341-08-12D	2.81	2.25	1.00	.38	1.594	.718	.50	.34	3/8-16	2.000	.937	1.000	5/16-18 x 1	210	
<b>3/4</b>	<b>1</b>	6341-12-16D	3.25	2.81	1.25	.38	2.000	.937	.75	.41	7/16-14	2.250	1.093	1.250	3/8-16 x 1 1/4	214	
<b>3/4</b>	<b>1 1/4</b>	6341-12-20D	3.75	3.25	1.25	.38	2.000	.937	.75	.41	1/2-13	2.625	1.250	1.250	3/8-16 x 1 1/4	214	
<b>3/4</b>	<b>1 1/2</b>	6341-12-24D	4.50	3.25	1.50	.38	2.000	.937	.75	.41	5/8-11	3.125	1.437	1.250	3/8-16 x 1 1/2	214	
<b>1</b>	<b>1 1/4</b>	6341-16-20D	3.75	3.25	1.25	.38	2.250	1.093	1.00	.47	1/2-13	2.625	1.250	1.562	7/16-14 x 1 1/4	219	
<b>1</b>	<b>1 1/2</b>	6341-16-24D	4.50	3.25	1.50	.38	2.250	1.093	1.00	.47	5/8-11	3.125	1.437	1.562	7/16-14 x 1 1/2	219	
<b>1 1/4</b>	<b>1 1/2</b>	6341-20-24D	4.50	3.75	1.50	.38	2.625	1.250	1.25	.53	5/8-11	3.125	1.437	1.750	1/2-13 x 1 1/2	222	
<b>1 1/4</b>	<b>2</b>	6341-20-32D	5.25	4.50	1.75	.50	2.625	1.250	1.25	.53	3/4-10	3.812	1.750	1.750	1/2-13 x 1 3/4	222	
<b>1 1/2</b>	<b>2</b>	6341-24-32D	5.25	4.50	1.75	.50	3.125	1.437	1.50	.66	3/4-10	3.812	1.750	2.125	5/8-11 x 1 3/4	225	
<b>2</b>	<b>2 1/2<sup>②</sup></b>	6341-32-40D	7.00	5.25	2.00	.50	3.812	1.750	1.94	.78	7/8-9	4.875	2.312	2.500	3/4-10 x 2 1/4	228	

① Included: (4) Bolts, (4) Lock Washers, (2) O-Rings    ② Not included in SAE J518 specifications